

## Electronics Related Products Guide

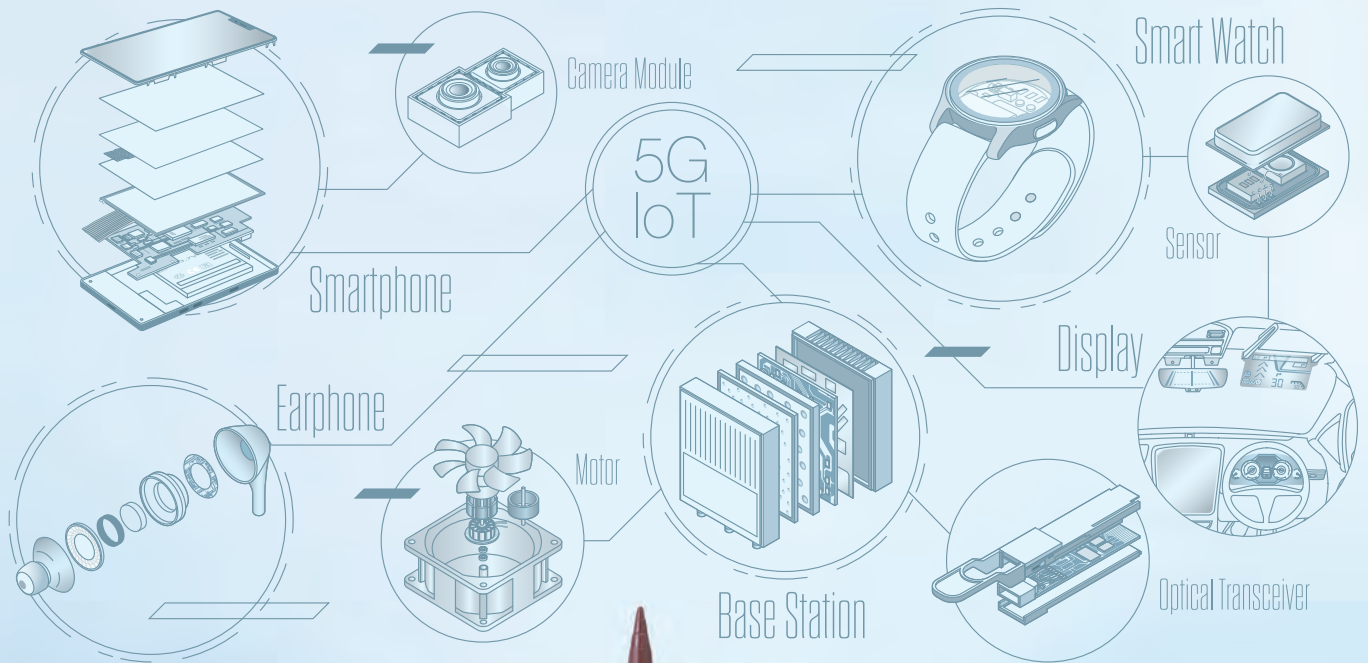

# DC Motor & Induction Motor

As the need for automation and labor saving increases, the number of small motors, which are key to their implementation, is also expected to increase. For the cases that requires high reliability, such as for robots, we can make proposals that are optimized for the operating environment.

## Motor with brush (DC, Universal)

### Commutator

|                 |  |
|-----------------|--|
| Application     | Bonding with shaft   |
| Product         | ThreeBond 1357K  |
| Characteristics | 1. High heat resistance (High Tg)<br>2. Fluorescence emission (Camera detectable)<br>3. Overflow can be UV-cured |
| Cure condition  | Anaerobic curing (added UV curability)   |
| Application     | Coil fraying prevention  |
| Product         | ThreeBond 2235L  |
| Characteristics | 1. High heat resistance (High Tg)<br>2. Low linear expansion   |
| Cure condition  | Heat curing  |

### Case

|                 |   |
|-----------------|---|
| Application     | Case sealing                                    |
| Product         | ThreeBond 1160<br>ThreeBond 1226                |
| Characteristics | 1. High heat resistance<br>2. Rubber elasticity |
| Cure condition  | Moisture curing                                 |

### Bearing

|                 |  |
|-----------------|--|
| Application     | Case and shaft bonding   |
| Product         | ThreeBond 1357K  |
| Characteristics | 1. High heat resistance (High Tg)<br>2. Fluorescence emission (Camera detectable)<br>3. Overflow can be UV-cured |
| Cure condition  | Anaerobic curing (added UV curability)   |

### Stator core

|                 |   |
|-----------------|---|
| Application     | Adhesive lamination   |
| Product         | ThreeBond 1360F   |
| Characteristics | 1. High heat resistance (High Tg)<br>2. Low viscosity<br>3. Curing can be accelerated with primer (ThreeBond 1390 series) |
| Cure condition  | Anaerobic curing  |

### Case

|                 |   |
|-----------------|---|
| Application     | Case sealing and adhesive                                       |
| Product         | ThreeBond 1535 Series   |
| Characteristics | 1. Strong adhesion to various materials<br>2. Rubber elasticity |
| Cure condition  | Moisture curing   |

### Choke coil

|                 |   |
|-----------------|---|
| Application     | Fixing  |
| Product         | ThreeBond 1535 Series   |
| Characteristics | 1. Strong adhesion to various materials<br>2. Rubber elasticity |
| Cure condition  | Moisture curing   |

### Rotor

|                 |   |
|-----------------|---|
| Application     | Balance weight  |
| Product         | ThreeBond 3084  |
| Characteristics | 1. High specific gravity (2.19)<br>2. High adhesion<br>3. Automation enabled through use of application equipment |
| Cure condition  | UV curing   |

## Induction motor

### Coil winding

|                 |  |
|-----------------|--|
| Application     | Fraying prevention                             |
| Product         | ThreeBond 1224G<br>ThreeBond 2285              |
| Characteristics | 1. High heat resistance<br>2. High flowability |
| Cure condition  | Moisture curing / Heat curing                  |

### Screw

|                 |   |
|-----------------|---|
| Application     | Fixing  |
| Product         | ThreeBond 2400Series (Pre-coated bolts / MEC)   |
| Characteristics | 1. Adheres simply from tightening<br>2. Excellent durability<br>3. Strength variation available |
| Cure condition  | Just tighten the bolts  |

# Brushless-DC Motor

Motors consume 50% of the world's electricity and increased miniaturization, rotation speed, and efficiency are progressing in response to demand for further increases in functionality. With these changes, the adhesives used require heat resistance and high strength.

## Inner rotor model

### Case

|                 |   |
|-----------------|---|
| Application     | Stator core bonding                                 |
| Product         | ThreeBond 2222P<br>ThreeBond 2237J                  |
| Characteristics | 1. High heat resistance<br>2. High thermal strength |
| Cure condition  | Heat curing   |

### Magnet

|                 |  |
|-----------------|--|
| Application     | Split magnet bonding   |
| Product         | ThreeBond 2049/2149<br>ThreeBond 3955  |
| Characteristics | 1. Room temperature curing by mixing two components (no heat source)<br>2. Flexibility (for adhesion of dissimilar materials)                        |
| Cure condition  | Two-component mixture  |
| Application     | IPM motor magnet bonding   |
| Product         | ThreeBond 2280H  |
| Characteristics | The adhesive can be expanded and fixed simply by applying it to the magnet and drying it in advance, then inserting it into the slot and heating it. |
| Cure condition  | Heat curing (expansion bonding)  |

### Fan (impeller, blades)

|                 |  |
|-----------------|--|
| Application     | Bonding with housing   |
| Product         | ThreeBond 7737   |
| Characteristics | 1. Excellent adhesion with plastics<br>2. High peel adhesion |
| Cure condition  | Moisture curing (instant bonding)                            |

### Magnet

|                 |   |
|-----------------|---|
| Application     | Split magnet bonding  |
| Product         | ThreeBond 2049/2149<br>ThreeBond 3955   |
| Characteristics | 1. Room temperature curing by mixing two components (no heat source)<br>2. Flexible cured material (for adhesion of dissimilar materials) |
| Cure condition  | Two-component mixture   |
| Application     | Ring magnet bonding   |
| Product         | ThreeBond 1357K<br>ThreeBond 1375N  |
| Characteristics | 1. Room temperature bonding<br>2. Overflow can be UV-cured  |
| Cure condition  | Anaerobic curing (added UV curability)  |

### Stepper motor

|                 |   |
|-----------------|---|
| Application     | Burr prevention during rotor core cutting       |
| Product         | ThreeBond 3042<br>ThreeBond 3057 Series         |
| Characteristics | 1. Low viscosity<br>2. Good cutting workability |
| Cure condition  | UV curing                                       |

### Control board

|                 |   |
|-----------------|---|
| Application     | Surface coating   |
| Product         | ThreeBond 3164D   |
| Characteristics | 1. Flexible cured material<br>2. Curable in shade using moisture curing |
| Cure condition  | UV curable (added moisture curability)                                  |

## Outer rotor model (fan)

### Bearing

|                 |   |
|-----------------|---|
| Application     | Bonding with shaft  |
| Product         | ThreeBond 1357K   |
| Characteristics | 1. High heat resistance (High Tg)<br>2. Fluorescence emission (Camera detectable) |
| Cure condition  | Anaerobic curing (added UV curability)  |
| Application     | Bonding with central tower  |
| Product         | ThreeBond 7737  |
| Characteristics | 1. Excellent adhesion with plastics<br>2. High peel adhesion                      |
| Cure condition  | Moisture curing (instant bonding)   |

# Smartphone

Smart phones that are now essential goods for daily living are composed of a lot of electronic components and modules and lots of glue. Attachment of a cover panel to a display panel with a UV-curable sheet-like adhesive enables a screen to be easily watched, and use of a low-temperature

curable/UV-curable sealant for a case can produce "waterproof and drip-proof" devices.

In addition, ThreeBond's sealants and adhesives contribute to making smart phones and their electronic components and modules thinner and more sophisticated.

Smartphone

## Fingerprint sensor

|                 |   |
|-----------------|---|
| Application     | Folder fixing   |
| Product         | ThreeBond 2206S   |
| Characteristics | 1. Curing at 80°C for 30 min<br>2. High strength of adhesion to resin materials |
| Cure condition  | Heat curing   |

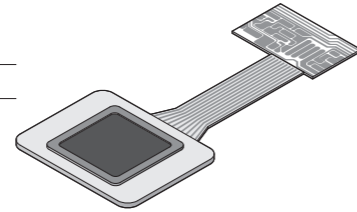

## Cover panel

|                 |  |
|-----------------|--|
| Application     | Cover panel circumference adhesion   |
| Product         | ThreeBond 1539 Series  |
| Characteristics | 1. Reaction starts in one minute at about 60°C.<br>2. A plant-based material is used.<br>3. Elasticity in a wide temperature range (-35 to 100°C). |
| Cure condition  | Heat curing  |

|                 |  |
|-----------------|--|
| Application     | Cover panel end face coating   |
| Product         | ThreeBond 3020B<br>ThreeBond 3027J<br>ThreeBond 3120B  |
| Characteristics | 1. High strength of adhesion to glass and resin<br>2. Black (Optical Density:1.6~/250µm)<br>3. Deep curability |
| Cure condition  | UV curing  |

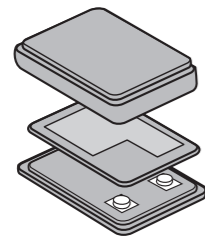

## Crystal device

|                 |  |
|-----------------|--|
| Application     | Crystal piece conduction and fixing                                  |
| Product         | ThreeBond 3304J  |
| Characteristics | 1. Good thermal reliability<br>2. Minute-amount application possible |
| Cure condition  | Heat curing  |

## Vibrating motor

|                 |  |
|-----------------|--|
| Application     | Magnet fixing  |
| Product         | ThreeBond 1357K/1390R<br>ThreeBond 2206S             |
| Characteristics | Fast-curing property                                 |
| Cure condition  | Anaerobic curing (added UV curability) / Heat curing |

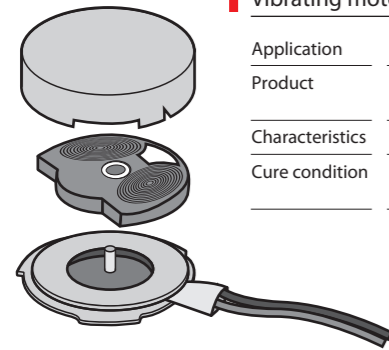

## Case

|                 |   |
|-----------------|---|
| Application     | Waterproof and drip-proof sealing                                   |
| Product         | ThreeBond 3081 Series<br>ThreeBond 3166                             |
| Characteristics | 1. Enables creation of sealing layers of any shape<br>2. Reworkable |
| Cure condition  | UV curing (CIPG)  |

\* CIPG (Cured In Place Gasket)

## Touch sensor / Display panel

|                 |  |
|-----------------|--|
| Application     | Sticking Cover panel / Touch sensor / Display panel  |
| Product         | ThreeBond 1631   |
| Characteristics | 1. Sheet-like adhesive<br>2. Heat before curing in order to follow level differences<br>3. High transparency |
| Cure condition  | UV curing  |

|                 |  |
|-----------------|--|
| Application     | Grounding  |
| Product         | ThreeBond 3331D<br>ThreeBond 3350C                 |
| Characteristics | 1. Fast-curing property<br>2. Low resistance value |
| Cure condition  | Heat curing / Room temperature dry type            |

|                 |                                    |
|-----------------|------------------------------------|
| Application     | FPC reinforcement                  |
| Product         | ThreeBond 3027G                    |
| Characteristics | 1. High adhesion<br>2. Flexibility |
| Cure condition  | UV curing                          |

|                 |  |
|-----------------|--|
| Application     | Grounding  |
| Product         | ThreeBond 3333F  |
| Characteristics | 1. Curing at 80°C for 60 min<br>2. High elongation rate (flexible) |
| Cure condition  | Heat curing  |

## Camera module

|                 |   |
|-----------------|---|
| Application     | Lens fixing   |
| Product         | ThreeBond 3020B   |
| Characteristics | 1. High strength of adhesion to glass and resin<br>2. Blackening after UV irradiation |
| Cure condition  | UV curing   |

|                 |  |
|-----------------|--|
| Application     | Grounding  |
| Product         | ThreeBond 3331D  |
| Characteristics | 1. Curing at 80°C for 60 min<br>2. Low resistance value<br>3. JET application compatible |
| Cure condition  | Heat curing  |

|                 |  |
|-----------------|--|
| Application     | IR cut-off filter fixing   |
| Product         | ThreeBond 3170B  |
| Characteristics | 1. Fast-curing property<br>2. High strength of adhesion to resin materials |
| Cure condition  | Visible light or UV curing   |

## IC

|                 |  |
|-----------------|--|
| Application     | IC heat dissipation  |
| Product         | ThreeBond 1225 Series  |
| Characteristics | 1. High thermal conductivity (1.59 to 2.5W/m-K)<br>2. Low molecular weight cyclic siloxane reduced product |
| Cure condition  | Moisture curing  |

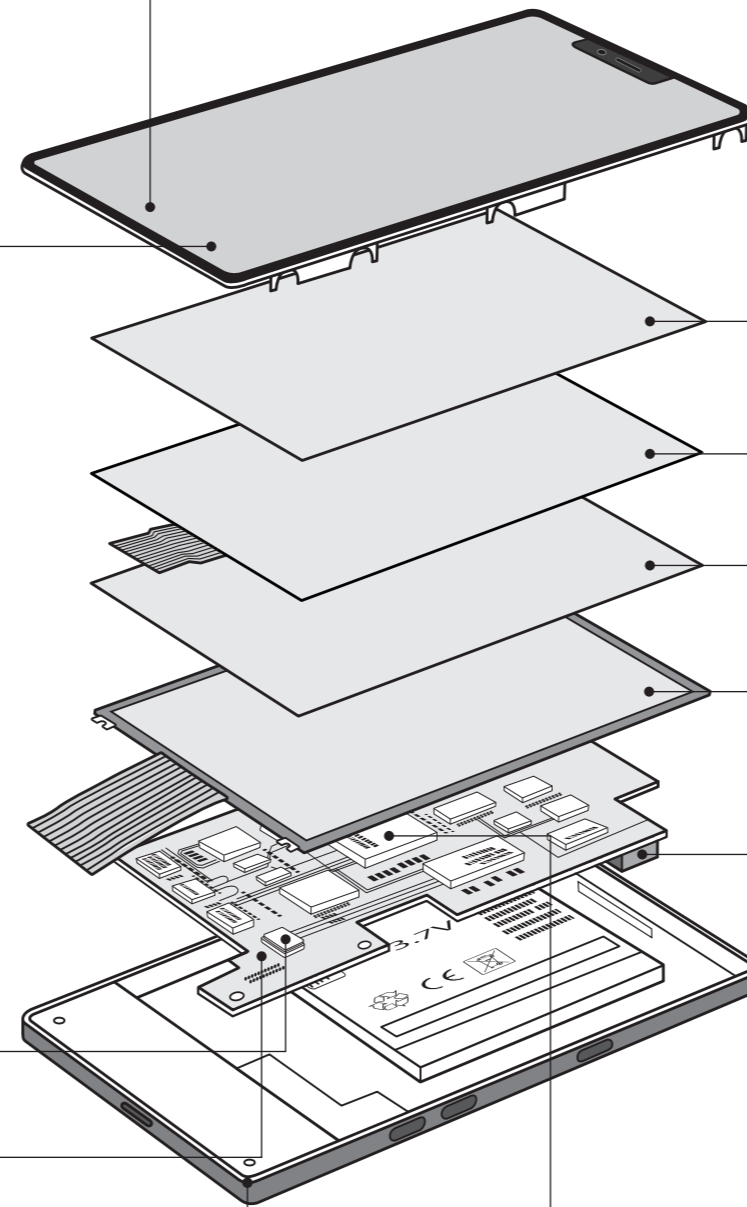
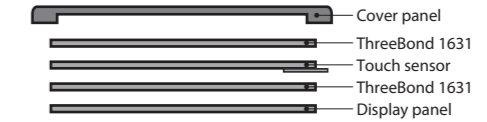

# Smart Watch

Many adhesives are also used in typical wearable devices, such as smartwatches. Electronic parts and modules that are equipped in smart watches are similar to those for smart phones and tablets, however, needs for adhesives change little by little due to downsizing.

Among them, "fine application to small-size electronic parts", "heating prevention" and "waterproofing and drip-proofing" can be named as needs. With our technology and products that have been cultivated over many years, ThreeBond's sealants and adhesives can meet all needs.

Camera Module

## Display

|                 |  |
|-----------------|--|
| Application     | Sticking Cover panel / Touch sensor / Display panel  |
| Product         | ThreeBond 1631   |
| Characteristics | 1. Sheet-like adhesive<br>2. Heat before curing in order to follow level differences<br>3. High transparency |
| Cure condition  | UV curing  |

|                 |                                    |
|-----------------|------------------------------------|
| Application     | FPC reinforcement                  |
| Product         | ThreeBond 3027G                    |
| Characteristics | 1. High adhesion<br>2. Flexibility |
| Cure condition  | UV curing                          |

|                 |  |
|-----------------|--|
| Application     | Grounding  |
| Product         | ThreeBond 3331D<br>ThreeBond 3350C                 |
| Characteristics | 1. Fast-curing property<br>2. Low resistance value |
| Cure condition  | Heat curing / Room temperature dry type            |

|                 |  |
|-----------------|--|
| Application     | Grounding  |
| Product         | ThreeBond 3333F  |
| Characteristics | 1. Curing at 80°C for 60 min<br>2. High elongation rate (flexible) |
| Cure condition  | Heat curing  |



## Cover panel

|                 |  |
|-----------------|--|
| Application     | Cover panel end face coating   |
| Product         | ThreeBond 3020B<br>ThreeBond 3027J<br>ThreeBond 3120B  |
| Characteristics | 1. High strength of adhesion to glass and resin<br>2. Black (Optical Density:1.6~/250μm)<br>3. Deep curability |
| Cure condition  | UV curing  |

|                 |  |
|-----------------|--|
| Application     | Cover panel circumference adhesion   |
| Product         | ThreeBond 1535 Series<br>ThreeBond 3074C                                       |
| Characteristics | 1. High strength of adhesion to glass and metal<br>2. High sealing performance |
| Cure condition  | Moisture curing / UV curing  |

## Vibrating motor

|                 |  |
|-----------------|--|
| Application     | Magnet fixing  |
| Product         | ThreeBond 1357K/1390R<br>ThreeBond 2206S             |
| Characteristics | 1. Fast-curing property<br>2. Shadow-zone curability |
| Cure condition  | Anaerobic curing (added UV curability) / Heat curing |

|                 |   |
|-----------------|---|
| Application     | Coil and FPC fixing   |
| Product         | ThreeBond 2206S<br>ThreeBond 3065E                            |
| Characteristics | 1. Fast-curing property<br>2. Adhesion to different materials |
| Cure condition  | Heat curing / UV curing (added Anaerobic curability)          |

## Li ion secondary battery

|                 |  |
|-----------------|--|
| Application     | Fixing   |
| Product         | ThreeBond 1535 Series  |
| Characteristics | 1. Adhesion to different materials<br>2. Elasticity is generated in a wide temperature range (-35 to 100°C). |
| Cure condition  | Moisture curing  |

## Substrate

|                 |                                 |
|-----------------|---------------------------------|
| Application     | Vibration-proof parts fixing    |
| Product         | ThreeBond 1535                  |
| Characteristics | Adhesion to different materials |
| Cure condition  | Moisture curing                 |

|                 |   |
|-----------------|---|
| Application     | Substrate surface coating   |
| Product         | ThreeBond 3164D   |
| Characteristics | 1. Flexible cured material<br>2. Curable in shade using moisture curing |
| Cure condition  | UV curable (added moisture curability)                                  |

## Crystal device

|                 |  |
|-----------------|--|
| Application     | Crystal piece conduction and fixing                                  |
| Product         | ThreeBond 3304J  |
| Characteristics | 1. Good thermal reliability<br>2. Minute-amount application possible |
| Cure condition  | Heat curing  |

## IC

|                 |  |
|-----------------|--|
| Application     | IC heat dissipation  |
| Product         | ThreeBond 1225 Series  |
| Characteristics | 1. High thermal conductivity (1.59 to 2.5W/m·K)<br>2. Low molecular weight cyclic siloxane reduced product |
| Cure condition  | Moisture curing  |

## Case

|                 |   |
|-----------------|---|
| Application     | Waterproof and drip-proof sealing                                   |
| Product         | ThreeBond 3081 Series<br>ThreeBond 3166                             |
| Characteristics | 1. Enables creation of sealing layers of any shape<br>2. Reworkable |
| Cure condition  | UV curing (CIPG)  |

\* CIPG (Cured In Place Gasket)

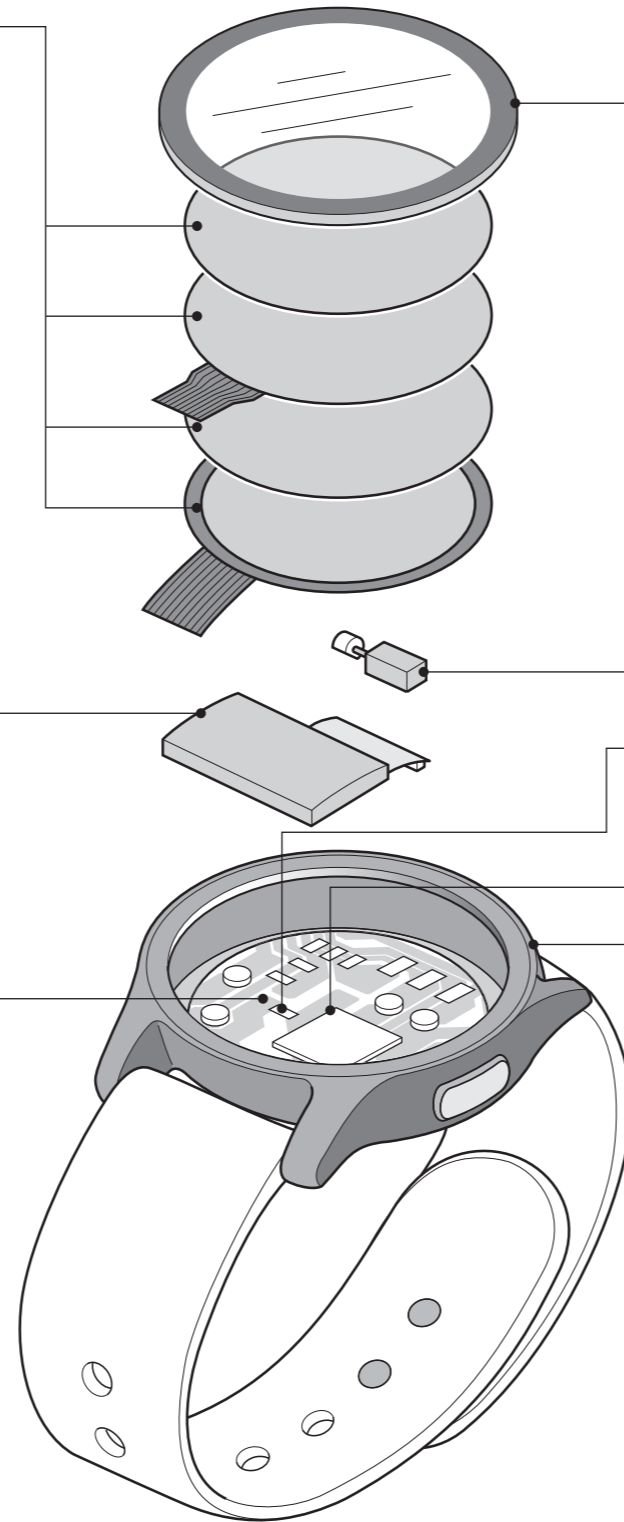

# Camera Module

A lot of adhesives are used for small-size camera modules installed in smart phones and tablets. Since the number of manufactured small-size camera modules is large, adhesives that cure fast at low temperature are needed to shorten the

manufacturing processes.

ThreeBond can provide a lineup of products, each of which is suitable to the desired location, to meet customer needs.

Camera Module

### Lens unit

|                 |   |
|-----------------|---|
| Application     | Lens fixing   |
| Product         | ThreeBond 3020B   |
| Characteristics | 1. High strength of adhesion to glass and resin<br>2. Blackening after UV irradiation |
| Cure condition  | UV curing   |

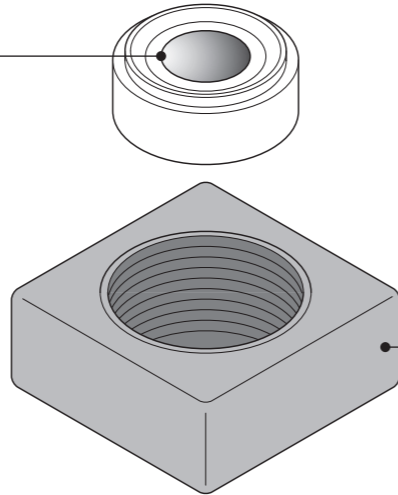

### Actuator

|                 |  |                 |   |
|-----------------|--|-----------------|---|
| Application     | Flat spring and Magnet fixing  | Application     | Others, fixing/sealing  |
| Product         | ThreeBond 2296B  | Product         | ThreeBond 2206S   |
| Characteristics | 1. Curing at 60 to 80°C for 30 min<br>2. Adhesion to different materials | Characteristics | 1. Curing at 80°C for 30 min<br>2. High strength of adhesion to resin materials |
| Cure condition  | Heat curing  | Cure condition  | Heat curing   |

### IR cut-off filter

|                 |   |
|-----------------|---|
| Application     | IR cut-off filter fixing  |
| Product         | ThreeBond 3170B   |
| Characteristics | 1. Fast curability<br>2. Deep curability<br>3. High strength of adhesion to resin materials |
| Cure condition  | Visible light or UV curing  |

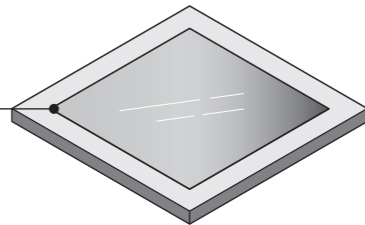

### Actuator

|                 |   |
|-----------------|---|
| Application     | Vibration absorption  |
| Product         | ThreeBond 3168E   |
| Characteristics | 1. High and low temperature resistance<br>2. Soft gel<br>3. Vibration absorbability |
| Cure condition  | UV curing   |

### Image sensor

|                 |   |
|-----------------|---|
| Application     | Active alignment (optical axis adjustment)                                |
| Product         | ThreeBond 3142  |
| Characteristics | 1. Dual cure<br>2. Low cure shrinkage rate<br>3. Thick coating curability |
| Cure condition  | UV curing + Heat curing   |

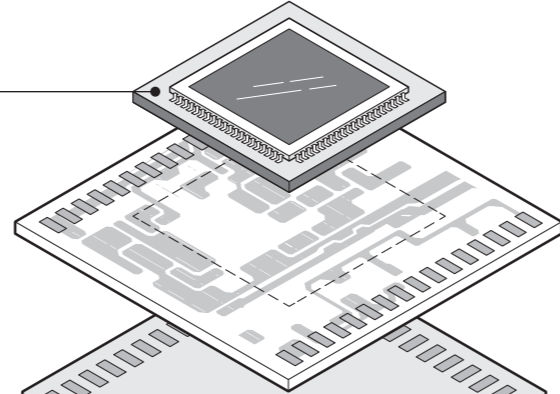

### FPC

|                 |  |
|-----------------|--|
| Application     | FPC reinforcement  |
| Product         | ThreeBond 2206S<br>ThreeBond 2296B                                       |
| Characteristics | 1. Curing at 60 to 80°C for 30 min<br>2. Adhesion to different materials |
| Cure condition  | Heat curing  |

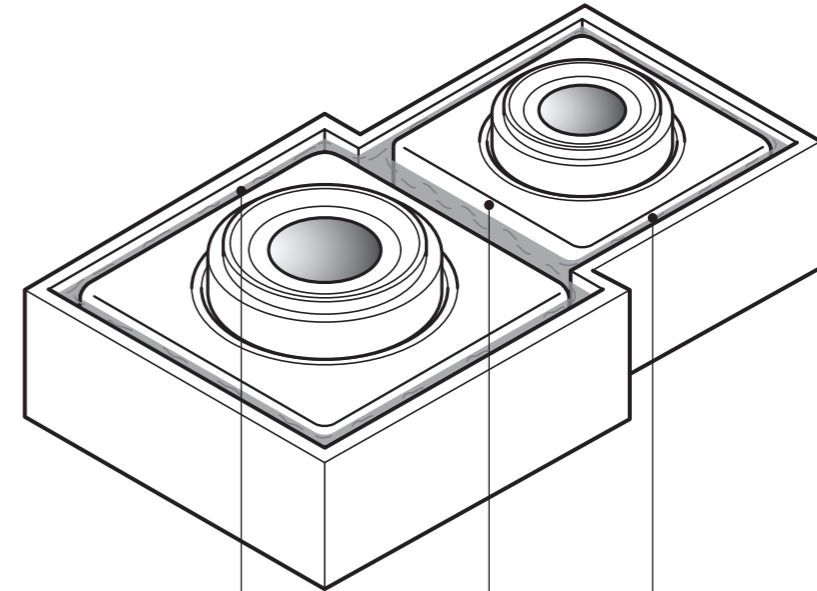
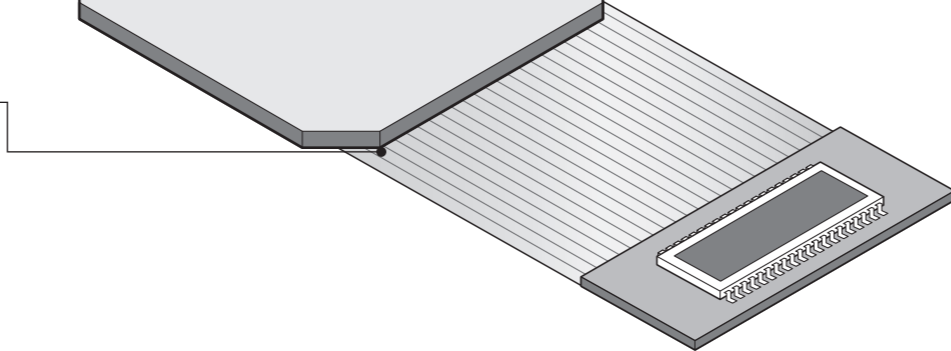

### Between camera / case

|                 |  |
|-----------------|--|
| Application     | Gap filling  |
| Product         | ThreeBond 1539<br>ThreeBond 2206S                    |
| Characteristics | 1. Low-temperature fast curing<br>2. Ideal flow rate |
| Cure condition  | Heat curing  |

### Between cameras, camera / case

|                 |   |
|-----------------|---|
| Application     | Grounding   |
| Product         | ThreeBond 3331D<br>ThreeBond 3333F                  |
| Characteristics | 1. Cures at low temperatures<br>2. High reliability |
| Cure condition  | Heat curing   |

# Digital Camera

A lot of adhesives are used for the mechanical components of cameras including a single lens reflex camera. As the design of a camera has been smaller and thinner, UV-LED light source-curable adhesives are needed in order to bond a different type of material to another, to reduce the amount

of heat applied to materials, and to reduce power consumption in camera manufacturing processes.

ThreeBond develops and manufactures adhesives that are the most appropriate to a customer's manufacturing processes and provide such products on a global basis.

Digital Camera

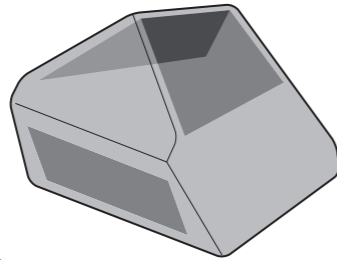

### Pentaprism

|                 |  |
|-----------------|--|
| Application     | Pentaprism fixing  |
| Product         | ThreeBond 3030 Series  |
| Characteristics | 1. High adhesion to resin materials (PC, PPS, etc.)<br>2. Flexible<br>3. Adhesion to different materials |
| Cure condition  | UV curing  |

### Strobe

|                 |   |
|-----------------|---|
| Application     | Strobe periphery fixing   |
| Product         | ThreeBond 1535 Series<br>ThreeBond 3164D  |
| Characteristics | 1. Good impact resistance<br>2. Adhesion to different materials<br>3. Shadow-zone curing possible |
| Cure condition  | Moisture curing / UV curing   |

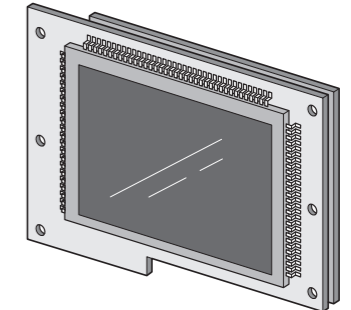

### Image sensor

|                 |  |
|-----------------|--|
| Application     | Image sensor fixing  |
| Product         | ThreeBond 3036 Series<br>ThreeBond 3114 Series   |
| Characteristics | 1. Low cure shrinkage<br>2. Low linear expansion coefficient<br>3. High adhesive strength  |
| Cure condition  | UV curing  |
| Application     | Heat dissipation   |
| Product         | ThreeBond 1225 Series<br>ThreeBond 2955 Series   |
| Characteristics | 1. High thermal conductivity (1.59 to 4.8W/m·K)<br>2. Low outgassing (TB 2955 Series)<br>3. Low molecular weight cyclic siloxane reduced product |
| Cure condition  | Moisture curing  |

### Glass and resin lens

|                 |   |
|-----------------|---|
| Application     | Bonding of lenses   |
| Product         | ThreeBond 3017 Series<br>ThreeBond 3020B  |
| Characteristics | 1. High strength of adhesion to materials difficult to bond (olefin-based)<br>2. Good surface curability<br>3. Less distortion (TB 3017 Series) |
| Cure condition  | UV curing   |

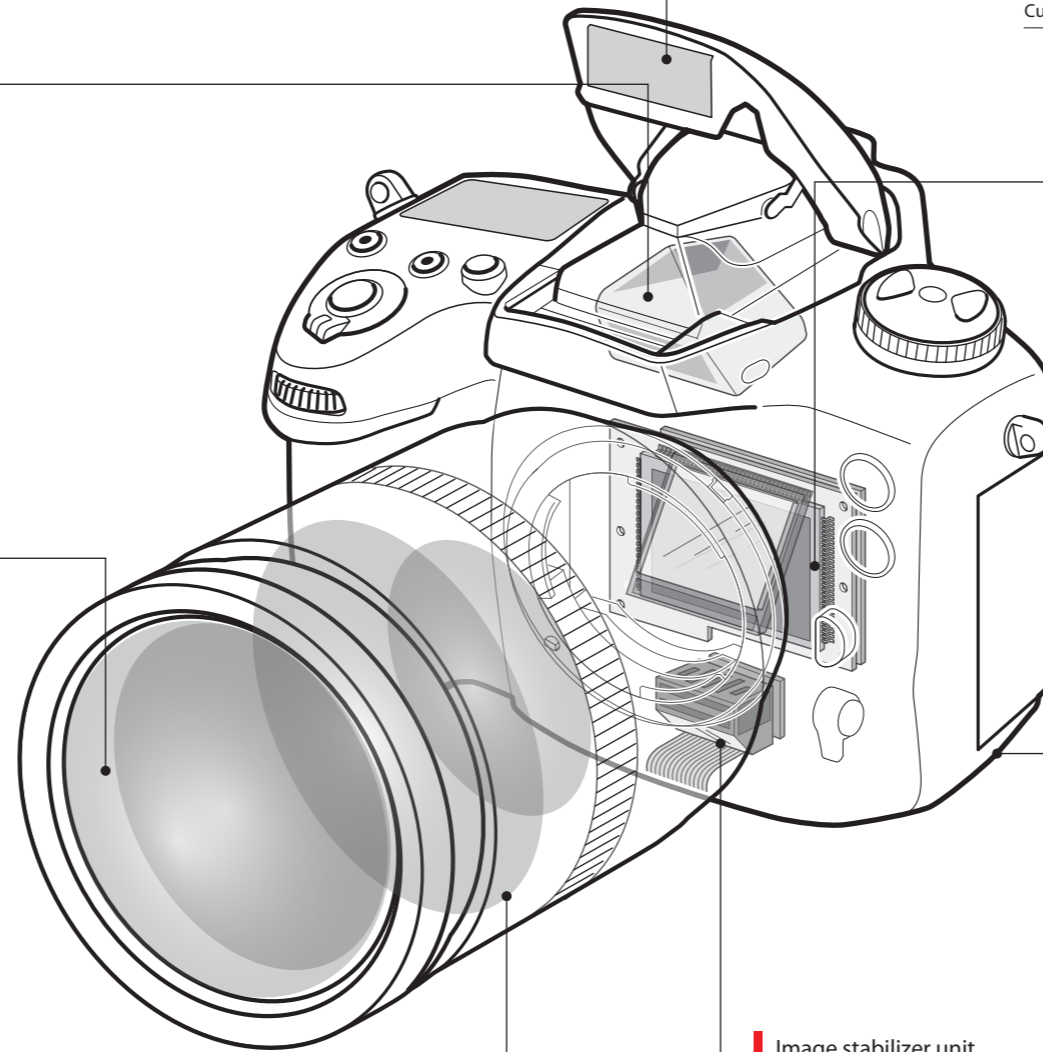

### Case / Lens mount

|                 |  |
|-----------------|--|
| Application     | Waterproof / Dustproof   |
| Product         | ThreeBond 3081 Series<br>ThreeBond 3166                                    |
| Characteristics | 1. Low compression permanent distortion<br>2. Flexibility<br>3. Reworkable |
| Cure condition  | UV curing (CIPG)   |

\* CIPG (Cured In Place Gasket)

### Image stabilizer unit

|                 |   |
|-----------------|---|
| Application     | Vibration absorption  |
| Product         | ThreeBond 3168E   |
| Characteristics | 1. High and low temperature resistance<br>2. Soft gel<br>3. Vibration absorbability |
| Cure condition  | UV curing   |

### AF sensor

|                 |  |
|-----------------|--|
| Application     | AF sensor fixing   |
| Product         | ThreeBond 1535 Series<br>ThreeBond 3017 Series   |
| Characteristics | 1. Good impact resistance<br>2. Adhesion to different materials<br>3. Shadow-zone curing possible (TB 1535 Series) |
| Cure condition  | Moisture curing / UV curing  |

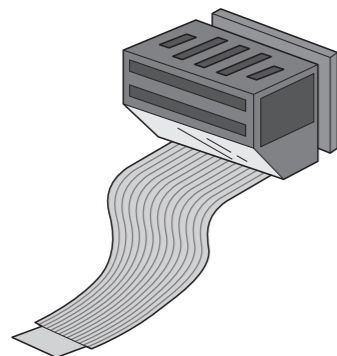

\* ThreeBond is abbreviated to TB.

# Surveillance Camera

In recent years, increasing awareness of global security has been accompanied by spreading adoption of surveillance cameras as a deterrent to crime and terrorism. For many years, our UV-curable resin has contributed to security cameras,

mainly to the adhesive application for optical parts. Increasing numbers of pixels in recent years have brought an increasing need for "thermal conductivity" as protection against overheating, and for "Sealants" as waterproofing and protection from insects.

Surveillance Camera

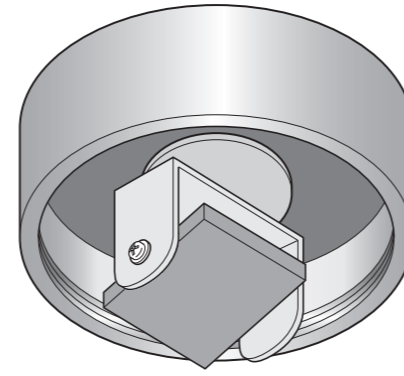

### Image sensor module

|                 |  |
|-----------------|--|
| Application     | Heat dissipation   |
| Product         | ThreeBond 1225 Series  |
| Characteristics | 1. High thermal conductivity (1.59 to 2.5W/m·K)<br>2. Low molecular weight cyclic siloxane reduced product |
| Cure condition  | Moisture curing  |

### Image sensor

|                 |   |
|-----------------|---|
| Application     | Image sensor fixing   |
| Product         | ThreeBond 3036 Series<br>ThreeBond 3114 Series  |
| Characteristics | 1. Low cure shrinkage<br>2. Low linear expansion coefficient<br>3. High adhesive strength |
| Cure condition  | UV curing   |

|                 |   |
|-----------------|---|
| Application     | Die bonding   |
| Product         | ThreeBond 3331D   |
| Characteristics | 1. Curing at 80°C for 60 min<br>2. Low resistivity<br>3. High reliability |
| Cure condition  | Heat curing   |

### Lens unit

|                 |   |
|-----------------|---|
| Application     | Lens fixing   |
| Product         | ThreeBond 3020B<br>ThreeBond 3030 Series  |
| Characteristics | 1. High adhesion to resin materials (PC, PPS, etc.)<br>2. Flexible<br>3. Bonding of a different type of material to another |
| Cure condition  | UV curing   |

### IR cut-off filter

|                 |   |
|-----------------|---|
| Application     | IR cut-off filter fixing  |
| Product         | ThreeBond 3170B   |
| Characteristics | 1. Fast curability<br>2. Deep curability<br>3. High strength of adhesion to resin materials |
| Cure condition  | Visible light or UV curing  |

### Top cover

|                 |  |
|-----------------|--|
| Application     | Water repellent coating  |
| Product         | ThreeBond 2907D  |
| Characteristics | 1. Single-component (silane-based)<br>2. Antifouling<br>3. Weather resistant |
| Cure condition  | Moisture curing  |

### Case

|                 |   |
|-----------------|---|
| Application     | Waterproof and drip-proof sealing                                   |
| Product         | ThreeBond 3081 Series<br>ThreeBond 3166                             |
| Characteristics | 1. Enables creation of sealing layers of any shape<br>2. Reworkable |
| Cure condition  | UV curing (CIPG)  |

\* CIPG (Cured In Place Gasket)

# Wireless Earphone

Wireless earphones are used for listening to music as well as during web conferences as telework becomes more prevalent, so production levels are increasing significantly. Furthermore, as earphones become more expensive, consumers expect them to last longer, so adhesives must improve productivity through "fast curing" and high reliability with a focus on "impact resistance".

Wireless Earphone

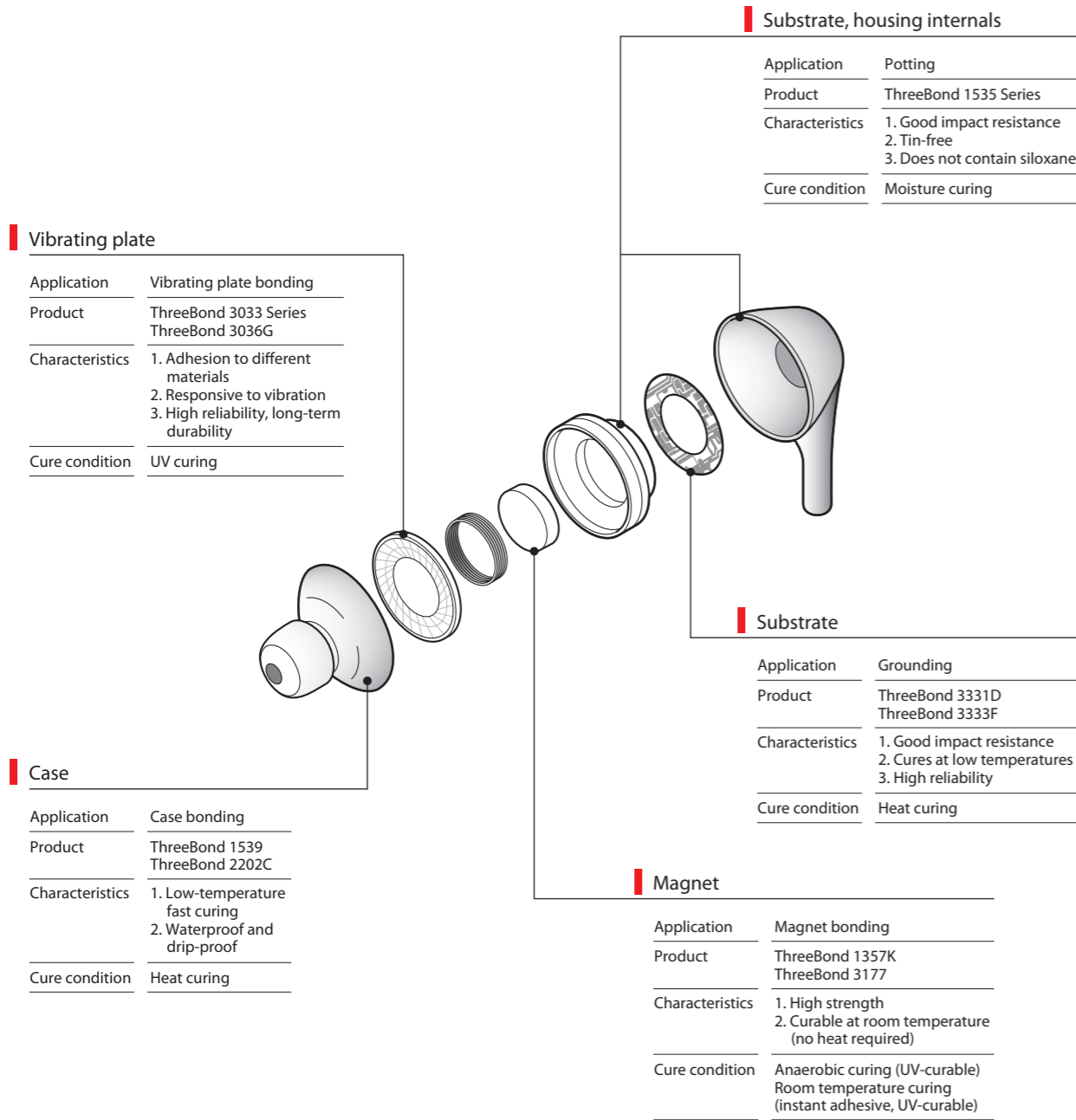

# Sensor / MEMS Device

Sensors and MEMS devices are used in a wide range of applications. As automation advances as a substitute for the five senses of human beings, adoption of these devices is expected to further increase. At ThreeBond, we propose the optimal products for sensors and MEMS devices that require high reliability.

Sensor / MEMS Device

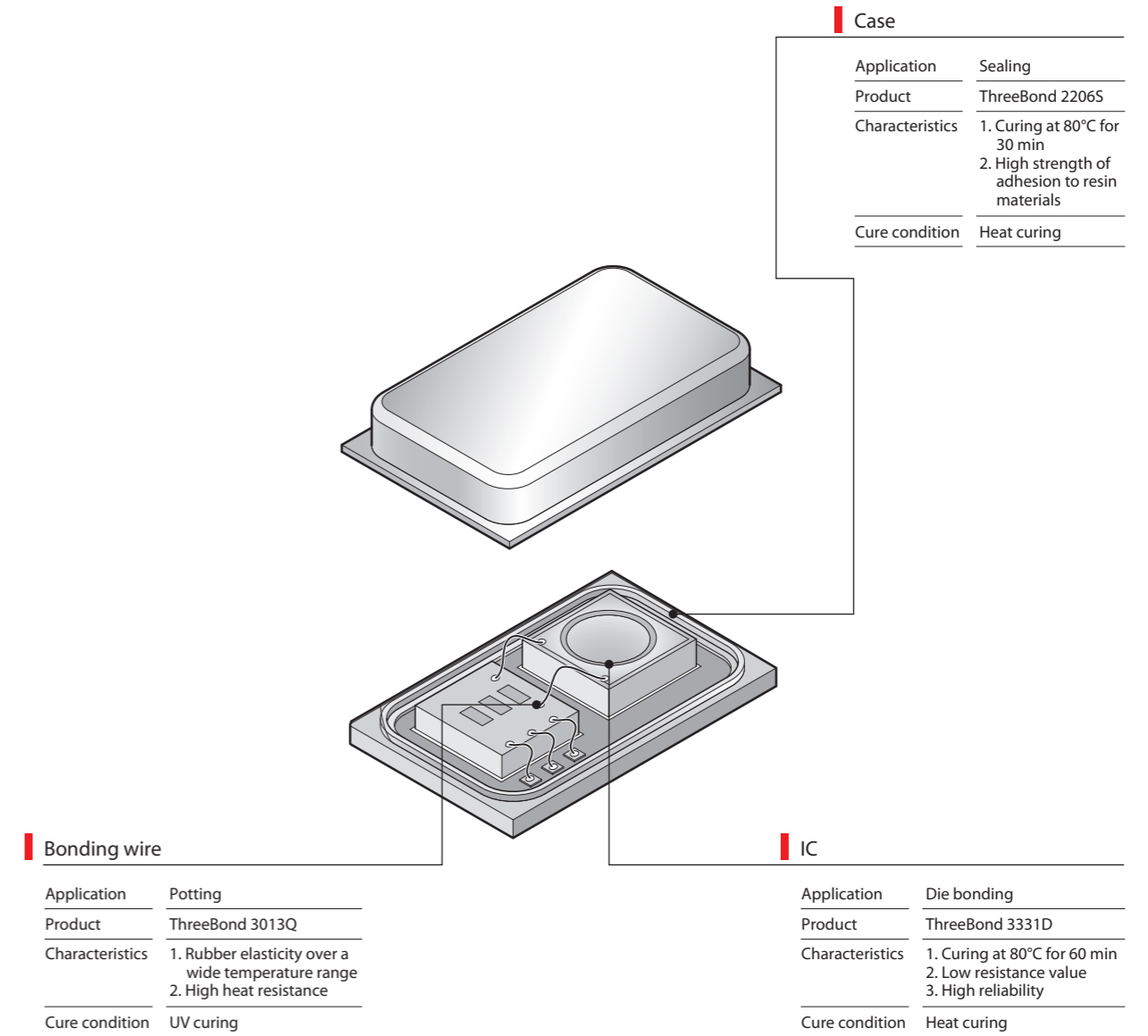



# 5G Base Station

Stations for 5G communication are starting to be set up everywhere, even outdoors, so adhesives must be incredibly reliable to ensure operation continues despite weather conditions. Our lineup includes case sealants, thermally conductive materials used to protect electronic substrates from heat and more.

5G Base Station

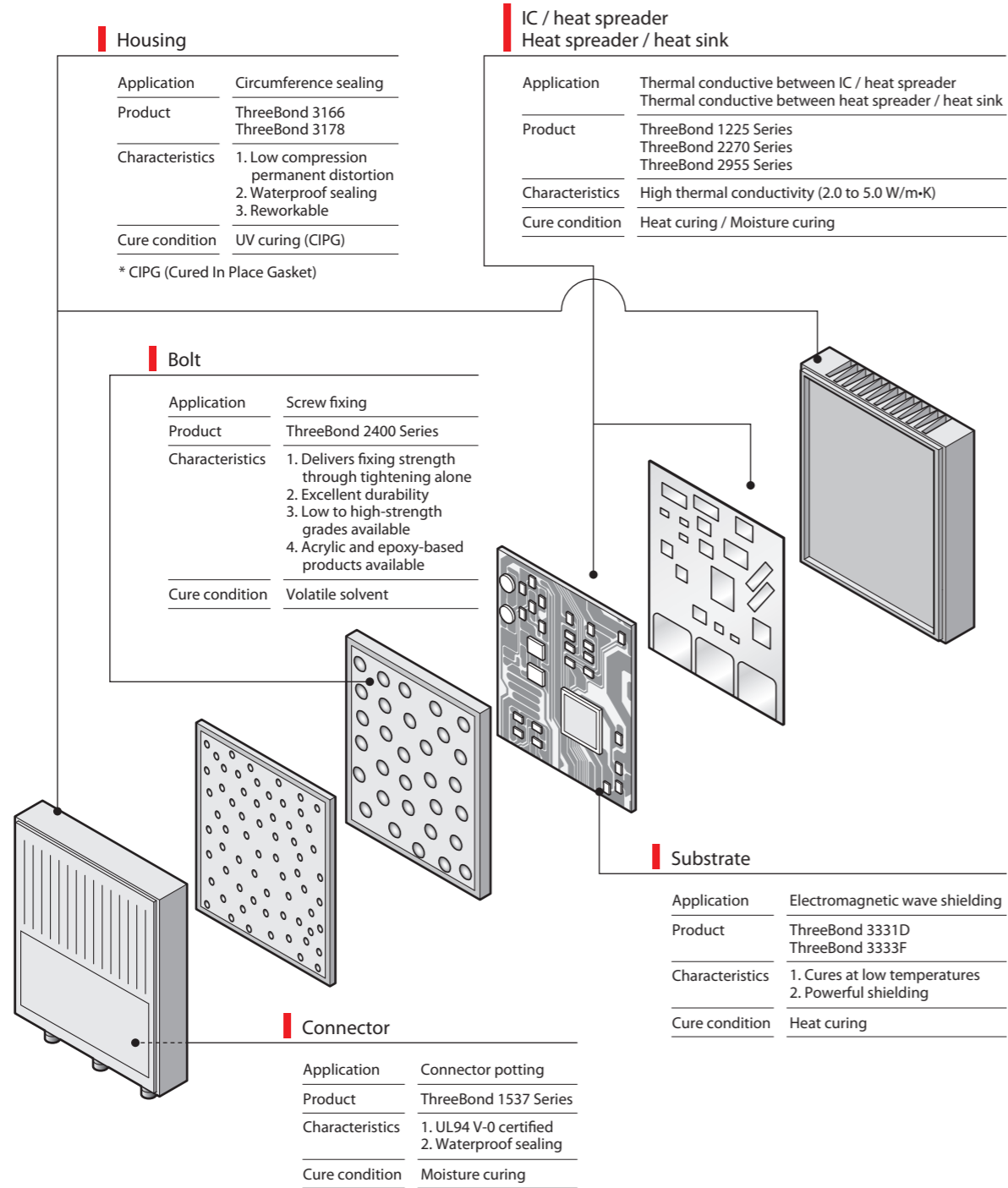

# Optical Transceiver

The spread of 5G communications has greatly increased the amount of data flying around the world. As for optical transceivers needed for high-speed communications, we have a wide range of products, mainly UV resins and heat-conducting materials for parts requiring precision fixation.

Optical Transceiver

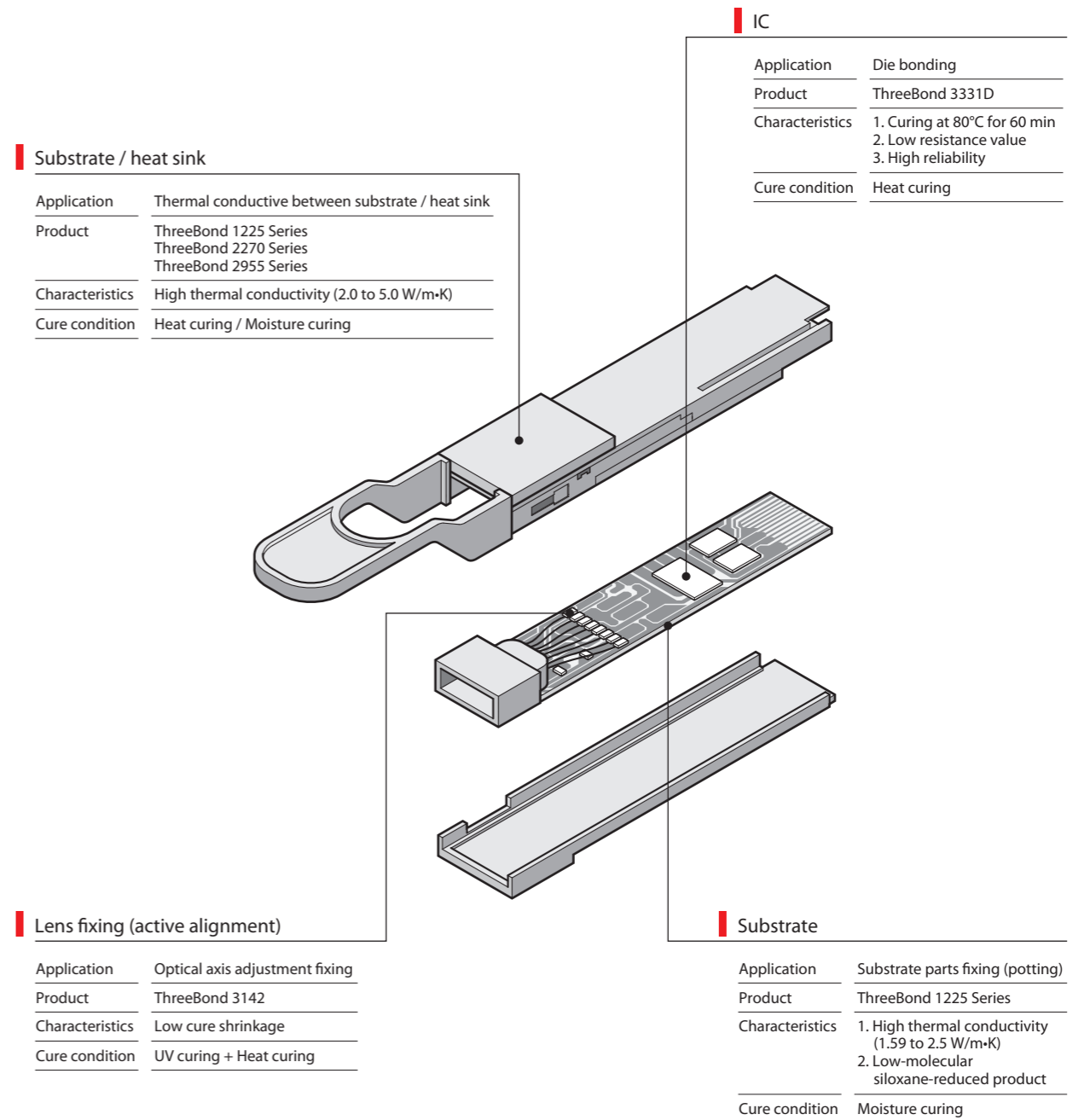

# Car Mounted Display / Camera

The number of on-board automobile displays and cameras have continued to increase as automotive electronics and safety performance improve. In the automotive field, heat resistance

and reliability must be higher than for general electronic equipment. ThreeBond utilizes our accumulated know-how to develop and produce adhesives and sealants that contribute to technological innovation in the automotive industry.

Car Mounted Display / Camera

## Car Mounted Camera

|                 |   |                 |   |
|-----------------|---|-----------------|---|
| Application     | Lens fixing   | Application     | Image sensor fixing   |
| Product         | ThreeBond 3036 Series<br>ThreeBond 3114 Series  | Product         | ThreeBond 2206S<br>ThreeBond 2270 Series  |
| Characteristics | 1. Bonds well to various adherend materials<br>2. Low cure shrinkage<br>3. High heat resistance | Characteristics | 1. Low cure shrinkage<br>2. Cures at low temperatures (TB2206S)<br>3. High thermal conductivity (TB2270 series) |
| Cure condition  | UV curing   | Cure condition  | Heat curing   |

## Head-Up Display

|                 |   |                 |   |
|-----------------|---|-----------------|---|
| Application     | Lens, mirror fixing   | Application     | Thermal conductive for control boards, fans, heat sinks   |
| Product         | ThreeBond 3036 Series<br>ThreeBond 3114 Series  | Product         | ThreeBond 1225 Series<br>ThreeBond 2270 Series  |
| Characteristics | 1. Bonds well to various adherend materials<br>2. Low cure shrinkage<br>3. High heat resistance | Characteristics | 1. High thermal conductivity<br>2. High heat resistance<br>3. High adhesive performance (TB2270 series) |
| Cure condition  | UV curing   | Cure condition  | Moisture curing / Heat curing   |

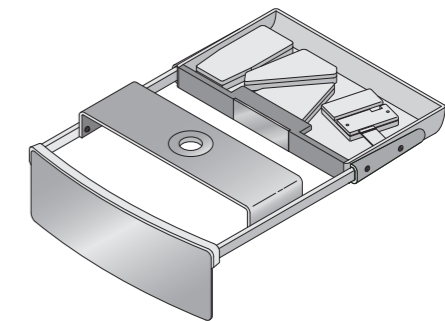
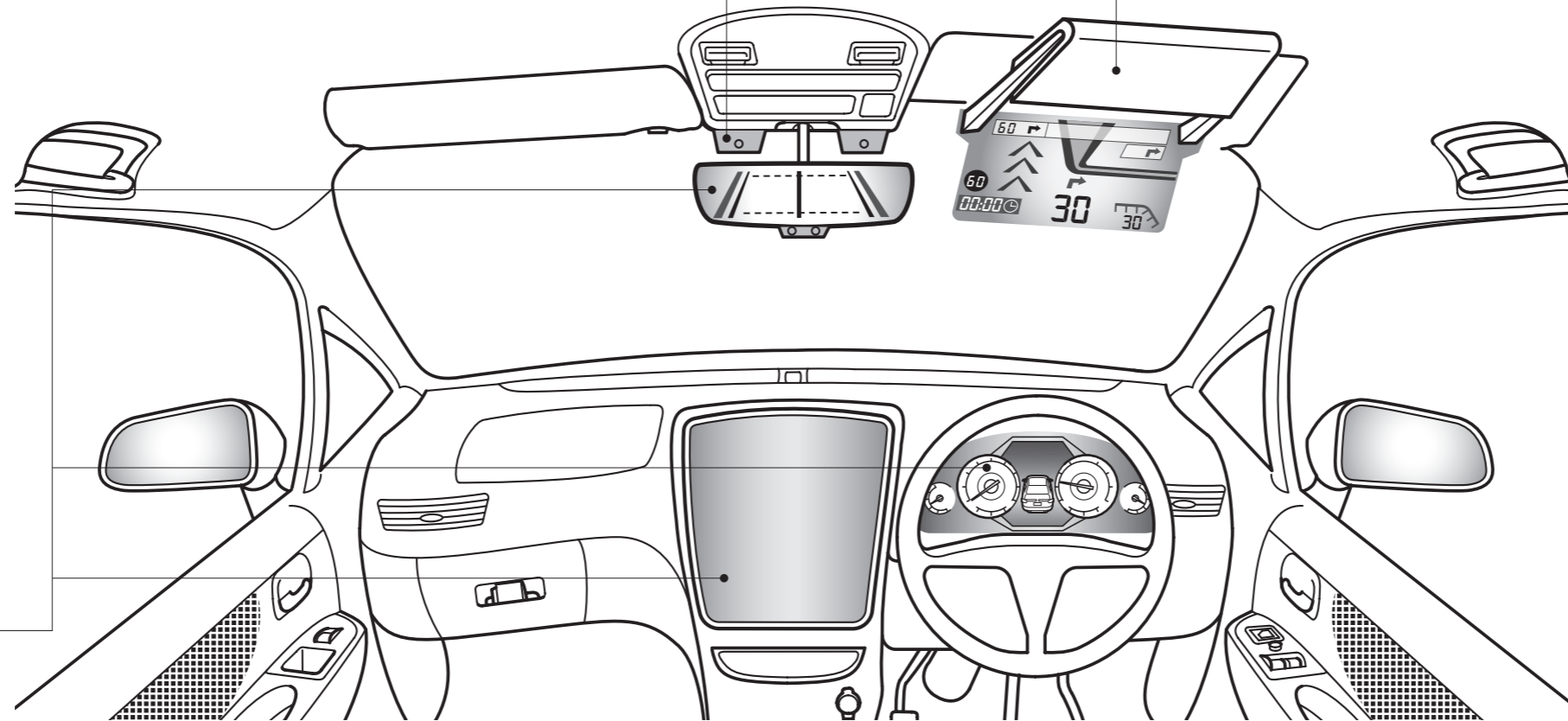
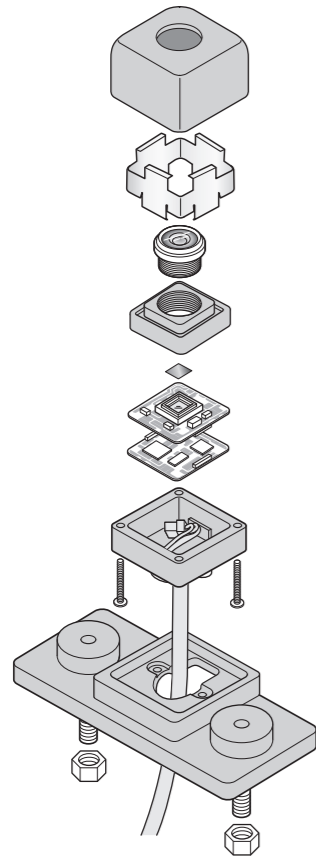

## Display

|                 |  |                 |  |                 |  |
|-----------------|--|-----------------|--|-----------------|--|
| Application     | Affixing of panels and parts   | Application     | Display panel end face coating   | Application     | Grounding                                |
| Product         | ThreeBond 1535 Series<br>ThreeBond 1539 Series   | Product         | ThreeBond 3020B<br>ThreeBond 3027J<br>ThreeBond 3120B  | Product         | ThreeBond 3331D<br>ThreeBond 3350C       |
| Characteristics | 1. Adhesion to different materials<br>2. Possible curing at 25°C (TB 1535)<br>3. 60°C x 1 min. until start of reaction (TB 1539) | Characteristics | 1. High strength of adhesion to glass and resin<br>2. Black (Optical Density:1.6~/250µm)<br>3. Deep curability | Characteristics | 1. Fast curability<br>2. Low resistivity |
| Cure condition  | Moisture curing / Heat curing  | Cure condition  | UV curing  | Cure condition  | Heat curing / Room temperature dry type  |

|                 |  |
|-----------------|--|
| Application     | Sticking Cover panel / touch sensors / display panels  |
| Product         | ThreeBond 1631   |
| Characteristics | 1. Sheet-like adhesive<br>2. Heat before curing in order to follow level differences<br>3. High transparency |
| Cure condition  | UV curing  |

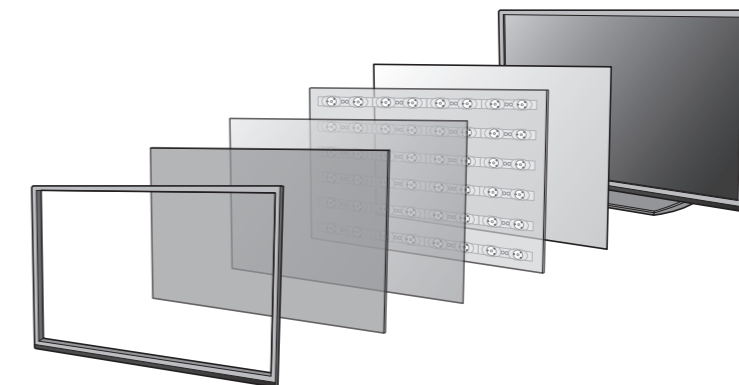

\* ThreeBond is abbreviated to TB.

ThreeBond has commercialized a lot of sealants that are applied to the junction surface of various types of flanges, screws, etc. of transportation equipment and industrial equipment to air-tighten and seal the inner fluid. Also in the battery field, the company uses its know-how about sealants to

thereby provide sealants for various types of batteries including alkaline batteries. Furthermore, in recent years, ThreeBond's sealants have been contributing to fuel cells and dye-sensitized solar cells that are paid attention to as the next-generation energy.

## Li Ion Secondary Battery / Alkaline Battery

### Li Ion Secondary Battery

|                 |  |
|-----------------|--|
| Application     | Liquid electrolyte sealing   |
| Product         | ThreeBond 1171 Series  |
| Characteristics | 1. Resistance to liquid electrolyte (PC, EC, etc.)<br>2. Low moisture permeability |
| Cure condition  | Solvent-vaporizing type  |

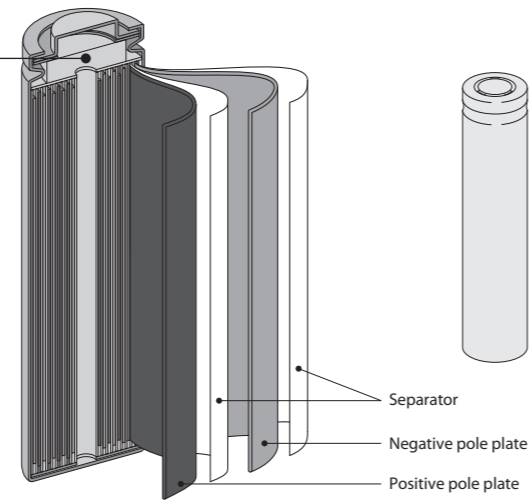

### Alkaline Battery

|                 |   |
|-----------------|---|
| Application     | Liquid electrolyte sealing  |
| Product         | ThreeBond 1170 Series<br>ThreeBond 1184 Series                            |
| Characteristics | 1. Resistance to liquid electrolyte (KOH)<br>2. Low moisture permeability |
| Cure condition  | Solvent-vaporizing type   |

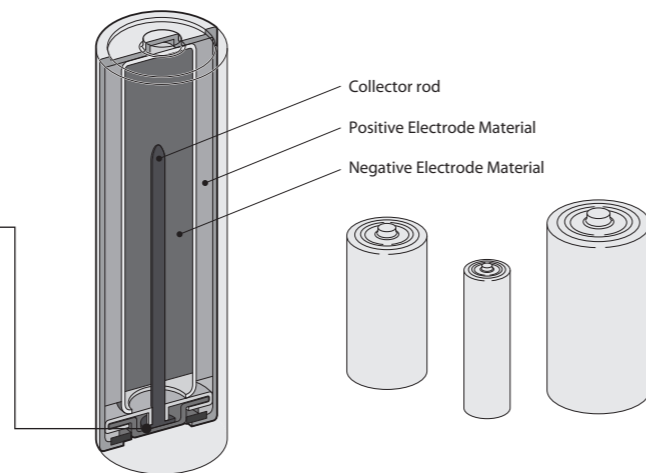

## Dye Sensitized Solar Battery / Fuel Battery

### Dye Sensitized Solar Battery

|                 |   |
|-----------------|---|
| Application     | Liquid electrolyte sealing  |
| Product         | ThreeBond 3035B<br>ThreeBond 3118   |
| Characteristics | 1. Resistance to liquid electrolyte (acetonitrile, GBL, PC, 3-MPN, etc.)<br>2. Low moisture permeability<br>3. High reliability |
| Cure condition  | UV curing /<br>UV curing (added Heat curability)  |

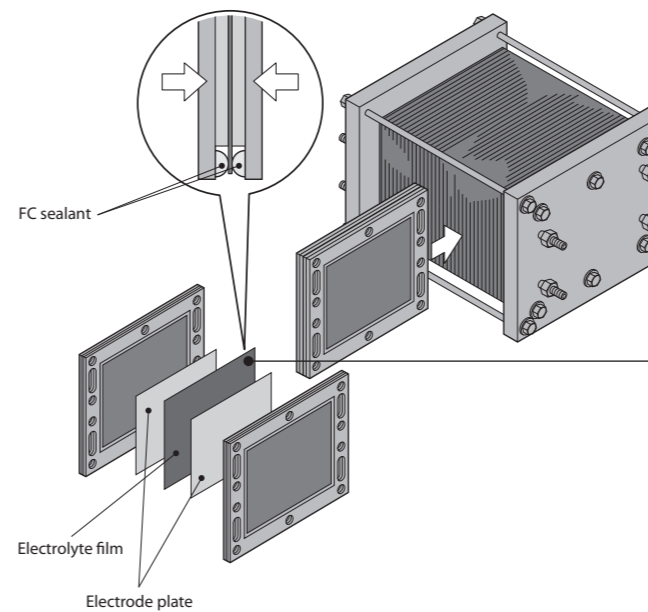
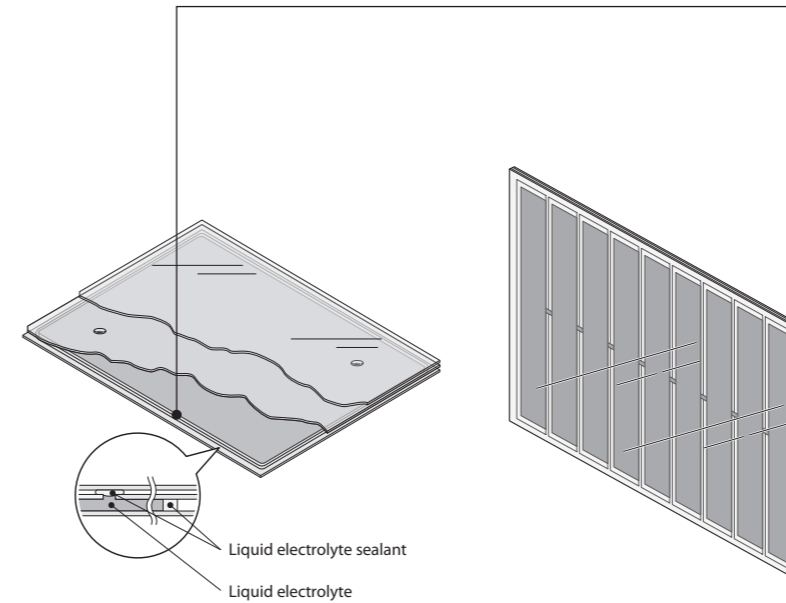

### Fuel Battery Seal

|                 |  |
|-----------------|--|
| Application     | Gas sealing  |
| Product         | ThreeBond 1153E<br>ThreeBond 3178  |
| Characteristics | 1. Chemical resistance (acid, alkaline)<br>2. Flexibility<br>3. Gas barrier property |
| Cure condition  | Heat curing / UV curing  |

# Product map by viscosity / hardness

Watch our video to see viscosity images



Viscosity comparison  
[Cyanoacrylate Adhesives]



Viscosity comparison  
[UV Curing Resins]



Viscosity comparison  
[Epoxy resin]

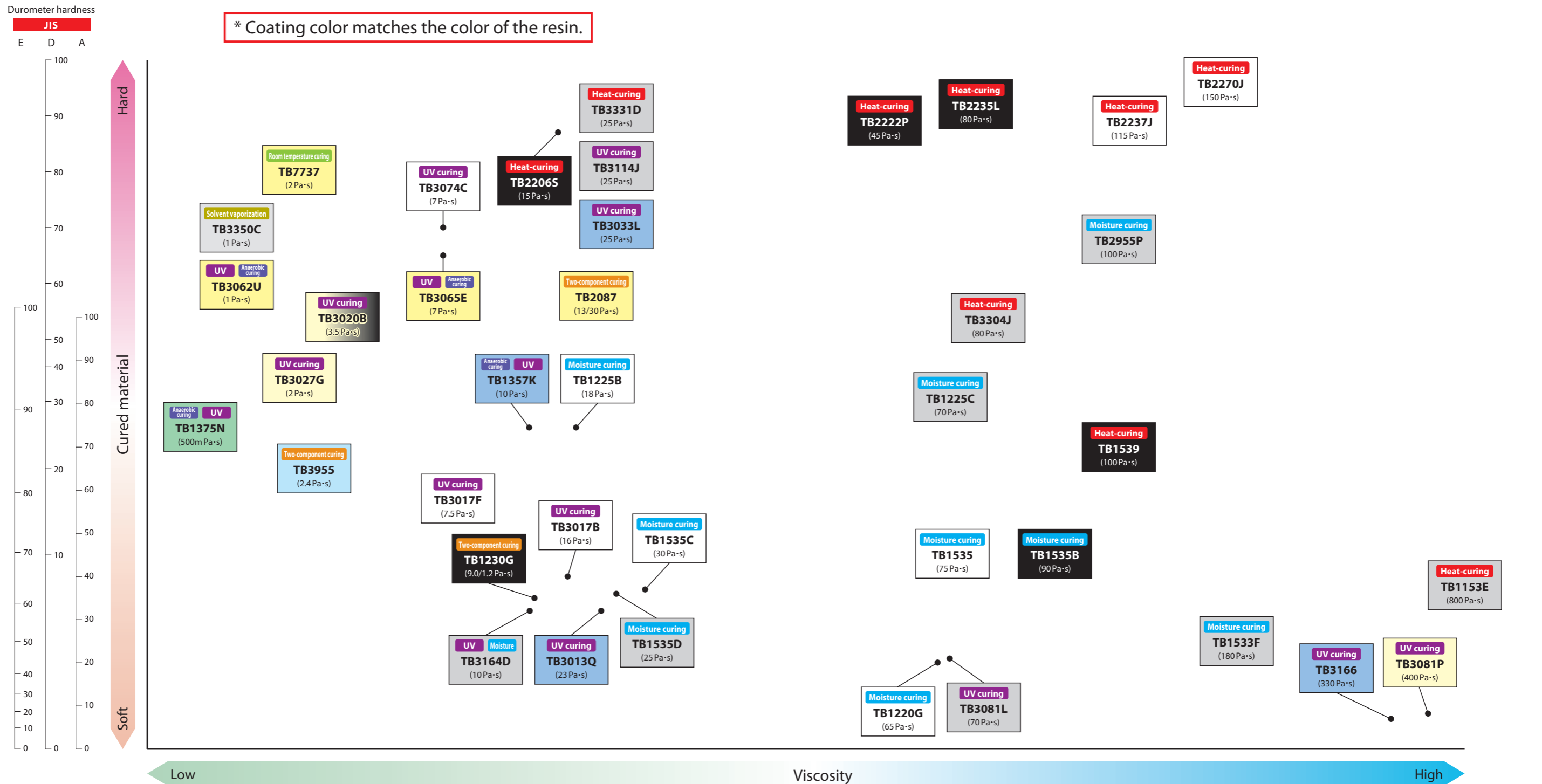

|                                  |   |                                    |   |  |  |
|----------------------------------|---|------------------------------------|---|--|--|
| Water<br>0.001 Pa·s<br>(1m Pa·s) | Simple syrup<br>1 Pa·s<br>(1,000m Pa·s) | Honey<br>15 Pa·s<br>(15,000m Pa·s) | Toothpaste<br>80 Pa·s<br>(80,000m Pa·s) | Mizuame<br>100 Pa·s<br>(100,000m Pa·s) | Peanut butter<br>250 Pa·s<br>(250,000m Pa·s) |
|----------------------------------|---|------------------------------------|---|--|--|

\* Viscosity at 25°C. Viscosity values are representative.  
 \* Viscosity of honey and toothpaste is approximate. Varies by manufacturer or brand.  
 \* 1 Pa·s (pascal-second) = 1,000 mPa·s (millipascal-second), 1 mPa·s = 1 cP (centipoise)

\* ThreeBond is abbreviated to TB.

# Adhesive selection table by material

## Tensile shear bond strength

| Curing method         | Materials       | Product Name | Conditions |         |        |         |               |        |        |        |
|-----------------------|-----------------|--------------|------------|---------|--------|---------|---------------|--------|--------|--------|
|                       |                 |              | TB1220G    | TB2082C | TB2087 | TB2088E | TB3921/TB3926 | TB3955 | TB7737 | TB7781 |
| At normal temperature | AL              | MPa          | 25°Cx24h   |         |        |         |               |        |        |        |
|                       | SUS304          |              | 1.0        | 12.8    | 3.7    | 3.1     | 1.3           | 2.0    | 20.4   | 14.9   |
|                       | Ni              |              | 1.0        | 20.4    | 15.4   | 9.4     | 18.2          | 6.2    | 18.2   | 12.2   |
|                       | Cu              |              | 2.7        | 14.6    | 13.6   | 10.4    | 17.1          | 3.5    | 26.8   | 13.3   |
|                       | LCP             |              | 1.0        | 14.7    | 15.6   | 9.9     | 8.3           | 2.9    | 20.3   | 12.7   |
|                       | PC              |              | 1.0        | 5.0     | 4.8    | 4.2     | 1.7           | 2.2    | -      | 1.2    |
|                       | PPS             |              | 1.4        | 3.8     | 4.7    | 3.7     | 0.4           | 1.2    | 6.2    | 6.9    |
|                       | PBT             |              | 1.3        | 2.8     | 2.3    | 1.8     | 1.5           | 1.3    | 3.2    | 1.9    |
|                       | PA66 (Nylon 66) |              | 1.8        | 2.7     | 2.7    | 2.0     | 1.7           | 1.4    | 2.4    | 4.3    |
|                       | Glass           |              | 1.3        | 3.8     | 4.9    | 2.6     | 2.1           | 2.3    | 11.9   | 13.1   |

| Curing method         | Materials       | Product Name | Conditions |         |        |         |                        |         |         |         |        |
|-----------------------|-----------------|--------------|------------|---------|--------|---------|------------------------|---------|---------|---------|--------|
|                       |                 |              | TB1354     | TB1357K | TB1533 | TB1533F | TB1535                 | TB1535B | TB1535C | TB1535D | TB1537 |
| At normal temperature | AL              | MPa          | 25°Cx24h   |         |        |         | 23°Cx50%RHx168h (7day) |         |         |         |        |
|                       | SUS304          |              | 0.5        | 0.5     | 5.7    | 1.4     | 5.7                    | 5.0     | 8.7     | 3.9     | 0.8    |
|                       | Ni              |              | 5.0        | 5.9     | 4.5    | 3.3     | 4.5                    | 4.1     | 5.7     | 3.6     | 3.8    |
|                       | Cu              |              | 8.6        | 11.8    | 4.0    | 3.8     | 4.0                    | 4.9     | 7.4     | 3.8     | 4.1    |
|                       | LCP             |              | 6.1        | 16.1    | 4.4    | 3.1     | 4.4                    | 4.0     | 5.6     | 3.5     | 3.8    |
|                       | PC              |              | -          | -       | 2.8    | 2.5     | 2.8                    | 2.2     | 2.2     | 1.8     | 1.1    |
|                       | PPS             |              | -          | -       | 3.1    | 3.9     | 3.1                    | 2.9     | 5.5     | 1.4     | 2.0    |
|                       | PBT             |              | -          | -       | 3.0    | 1.9     | 3.0                    | 2.2     | 1.7     | 3.1     | 0.8    |
|                       | PA66 (Nylon 66) |              | -          | -       | 1.0    | 2.7     | 1.0                    | 0.8     | 0.7     | 0.7     | 1.0    |
|                       | Glass           |              | -          | -       | 3.8    | 4.0     | 3.8                    | 3.3     | 4.0     | 2.9     | 3.7    |

| Curing method | Materials       | Product Name | Conditions |             |            |            |             |             |             |             |
|---------------|-----------------|--------------|------------|-------------|------------|------------|-------------|-------------|-------------|-------------|
|               |                 |              | TB1539     | TB2202C     | TB2206S    | TB2212Q    | TB2222P     | TB2235L     | TB2237J     | TB2247D     |
| Heating       | AL              | MPa          | 60°Cx90min | 120°Cx10min | 80°Cx30min | 80°Cx90min | 100°Cx60min | 140°Cx30min | 120°Cx60min | 150°Cx30min |
|               | SUS304          |              | 4.3        | 4.3         | 5.2        | 2.5        | 13.0        | 12.4        | 15.0        | 3.2         |
|               | Ni              |              | 2.7        | 15.0        | 12.2       | 9.1        | 25.9        | 20.3        | 24.0        | 28.1        |
|               | Cu              |              | 2.8        | 12.1        | 13.4       | 9.5        | 23.1        | 13.4        | 25.8        | 26.4        |
|               | LCP             |              | 3.3        | 12.6        | 11.4       | 8.1        | 18.1        | 17.9        | 18.0        | 26.0        |
|               | PC              |              | 2.2        | 7.3         | 6.1        | 7.8        | 7.7         | 6.2         | 8.0         | 6.4         |
|               | PPS             |              | 1.5        | 1.0         | 1.1        | 2.5        | 1.5         | 1.9         | 2.1         | 2.6         |
|               | PBT             |              | 1.9        | 3.7         | 2.5        | 2.9        | 5.5         | 3.9         | 5.3         | 5.2         |
|               | PA66 (Nylon 66) |              | 2.4        | 3.5         | 3.3        | 3.9        | 3.7         | 5.0         | 3.7         | 6.1         |
|               | Glass           |              | 0.7        | 4.4         | 3.6        | 2.4        | 6.1         | 4.2         | 2.8         | 3.6         |

| Curing method | Materials       | Product Name | Conditions  |             |            |
|---------------|-----------------|--------------|-------------|-------------|------------|
|               |                 |              | TB2270J     | TB2285      | TB2296B    |
| Heating       | AL              | MPa          | 100°Cx40min | 120°Cx60min | 80°Cx30min |
|               | SUS304          |              | 6.7         | 4.8         | 3.9        |
|               | Ni              |              | 8.8         | 18.1        | 18.3       |
|               | Cu              |              | 5.4         | 17.7        | 21.8       |
|               | LCP             |              | 7.0         | 15.3        | 21.3       |
|               | PC              |              | 8.0         | 7.3         | 4.6        |
|               | PPS             |              | 1.0         | 1.5         | 3.1        |
|               | PBT             |              | 4.0         | 4.9         | 2.0        |
|               | PA66 (Nylon 66) |              | 4.4         | 5.1         | 1.9        |
|               | Glass           |              | 2.1         | 5.7         | 3.0        |

| Curing method | Materials | Product Name | Conditions  |            |
|---------------|-----------|--------------|-------------|------------|
|               |           |              | TB3301W     | TB3331D    |
| Heating       | Au        | MPa          | 120°Cx60min | 80°Cx60min |
|               | AL        |              | 19.2        | 16.5       |
|               | Cu        |              | 2.8         | 7.6        |
|               | SUS       |              | 13.6        | 18.3       |
|               | Ni        |              | 12.1        | 13.0       |

\* Chip bond strength (ceramic chip)

| Curing method | Materials             | Product Name | Conditions             |         |         |                        |         |                        |         |        |
|---------------|-----------------------|--------------|------------------------|---------|---------|------------------------|---------|------------------------|---------|--------|
|               |                       |              | TB3013Q                | TB3017B | TB3017F | TB3020B                | TB3027G | TB3027J                | TB3033B | TB3036 |
| UV            | AL/Glass              | MPa          | 30kJ/m <sup>2</sup> UV |         |         | 60kJ/m <sup>2</sup> UV |         | 30kJ/m <sup>2</sup> UV |         |        |
|               | SUS304/Glass          |              | 3.2                    | 6.5     | 3.0     | 7.0                    | 3.5     | 0.8                    | 5.5     | 10.0   |
|               | Ni/Glass              |              | 4.4                    | 6.8     | 3.6     | 8.6                    | 5.7     | 3.6                    | 7.8     | 9.4    |
|               | Cu/Glass              |              | 8.5                    | 7.8     | 4.2     | 4.9                    | 5.1     | 6.4                    | 8.4     | 7.5    |
|               | LCP/Glass             |              | 5.4                    | 8.0     | 4.0     | 4.2                    | 6.1     | 3.2                    | 8.8     | 7.1    |
|               | PC/Glass              |              | 2.4                    | 5.6     | 3.3     | 5.3                    | 4.1     | 4.0                    | 4.6     | 5.1    |
|               | PPS/Glass             |              | 3.6                    | 4.0     | 2.7     | 7.1                    | 4.3     | 6.3                    | 7.5     | 6.4    |
|               | PBT/Glass             |              | 2.9                    | 6.3     | 3.6     | 3.8                    | 5.8     | 4.6                    | 5.4     | 6.6    |
|               | PA66 (Nylon 66)/Glass |              | 1.9                    | 4.5     | 2.7     | 4.0                    | 4.2     | 2.9                    | 2.6     | 3.8    |
|               | Glass/Glass           |              | 4.6                    | 6.4     | 3.3     | 3.2                    | 3.7     | 4.3                    | 5.8     | 4.8    |

| Curing method | Materials             | Product Name | Conditions             |         |         |         |         |        |         |         |         |
|---------------|-----------------------|--------------|------------------------|---------|---------|---------|---------|--------|---------|---------|---------|
|               |                       |              | TB3036G                | TB3056F | TB3062U | TB3065E | TB3074C | TB3114 | TB3114J | TB3164D | TB3170B |
| UV            | AL/Glass              | MPa          | 30kJ/m <sup>2</sup> UV |         |         |         |         |        |         |         |         |
|               | SUS304/Glass          |              | 4.7                    | 0.3     | 4.7     | 0.4     | 2.6     | 2.5    | 1.7     | -       | 7.0     |
|               | Ni/Glass              |              | 6.2                    | 2.7     | 7.3     | 7.9     | 5.4     | 7.8    | 4.1     | 2.6     | 9.9     |
|               | Cu/Glass              |              | 7.9                    | 3.7     | 8.2     | 9.0     | 4.7     | 6.4    | 4.4     | -       | 10.1    |
|               | LCP/Glass             |              | 7.4                    | 0.9     | 8.4     | 8.6     | 5.8     | 5.8    | 2.6     | 2.1     | 10.0    |
|               | PC/Glass              |              | 4.6                    | 3.1     | 3.9     | 4.0     | 5.5     | 3.5    | 5.4     | 1.4     | 6.4     |
|               | PPS/Glass             |              | 4.0                    | 3.6     | 7.1     | 8.3     | 3.9     | 6.1    | 2.1     | 3.1     | 7.4     |
|               | PBT/Glass             |              | 5.2                    | 3.6     | 6.6     | 5.1     | 6.1     | 4.8    | 4.6     | 3.4     | 7.0     |
|               | PA66 (Nylon 66)/Glass |              | 3.9                    | 3.1     | 2.8     | 2.9     | 3.9     | 6.7    | 4.8     | 2.4     | 4.5     |
|               | Glass/Glass           |              | 6.0                    | 3.7     | 5.0     | 7.5     | 3.0     | 5.1    | 1.5     | 2.9     | 3.7     |

\*The values shown in the characteristics table are examples from actual measurement values, not guaranteed values.  
\*ThreeBond is abbreviated to TB.

### For Motors

| Product name    | Volume      | Characteristics  |
|-----------------|-------------|--|
| ThreeBond 1160  | 480g        | Black / 125 Pa-s / Moisture curable, Non-silicone product, Tin-free  |
| ThreeBond 1224G | 95g         | Milky white/1.2Pa-s/alcohol-releasing type/low-viscosity   |
| ThreeBond 1226  | 330ml       | Gray/97Pa-s/alcohol-releasing type/Good for resin adhesive/Tin-free product                                |
| ThreeBond 1357K | 250g        | Blue/12Pa-s/Suitable for surface bonding, Fluorescence emission, Low-halogen product, with UV curing added |
| ThreeBond 1360F | 50g · 250g  | Green / 500 mPa-s / High strength, High heat resistance  |
| ThreeBond 1375N | 50g · 250g  | Green transparent/Interlocking part adhesive/500mPa-s/High strength/With UV curing added                   |
| ThreeBond 1535  | 170g · 470g | White/75Pa-s/Elastic adhesive/Tin-free product   |
| ThreeBond 2049  | 450g        | Main agent · Black, Curing agent · White / Flexible, high-adhesion type                                    |
| ThreeBond 2149  | 450g        |  |
| ThreeBond 2222P | 1kg         | Black/45Pa-s/Curing at 100°C for 60 min, impact-resistant type   |
| ThreeBond 2235L | 1kg         | Black/80Pa-s/Curing at 140°C for 30 min, high heat resistance, low linear expansion                        |
| ThreeBond 2237J | 1kg         | White/115Pa-s/Curing at 120°C for 60 min, high heat resistance, high adhesive strength                     |
| ThreeBond 2285  | 1kg         | Milky white/140Pa-s/Curing at 120°C for 60 min, heat resistance  |
| ThreeBond 2458  |             | MEC process for pre-coating both bolts and nuts, Low strength, Green                                       |
| ThreeBond 2468  |             | MEC process for pre-coating both bolts and nuts, Medium strength, Red                                      |
| ThreeBond 3042  | 250g        | Colorless and transparent/20mPa-s/low-viscosity/high hardness  |
| ThreeBond 3057  | 1kg         | turbid white/35Pa-s/added Heat curability  |
| ThreeBond 3084  | 250g        | Gray/100Pa-s/specific gravity 2.19/Good for shape retention/high adhesive strength                         |
| ThreeBond 3164D | 330ml       | Pale white/10Pa-s/UV- and moisture-curable silicone, potting agent   |
| ThreeBond 3955  | 50ml SET    | Two-component low-elasticity fast-curing acrylic resin/high heat resistance, high moisture resistance      |
| ThreeBond 7737  | 20g         | Light yellowish transparent/2.0Pa-s/Extremely high peel strength, impact-resistant type                    |

### For Smart Phones, Smart Watches, Earphones, Sensors and MEMS Devices

| Product name           | Volume       | Characteristics   |
|------------------------|--------------|---|
| ThreeBond 1225B        | 250g         | White/18Pa-s/Moisture-curable heat dissipating resin 1.59W/m-K  |
| ThreeBond 1225C        | 250g         | Gray/70Pa-s/high reliability heat dissipating resin 2.5W/m-K  |
| ThreeBond 1357K        | 250g         | Blue/12Pa-s/Suitable for surface bonding, Fluorescence emission, Low-halogen product, with UV curing added                              |
| ThreeBond 1390R        | 500ml        | Blue-greenish transparent/Curing accelerating agent for anaerobic sealing adhesives (ethanol type)                                      |
| ThreeBond 1530C        | 150g · 430g  | Translucent/100Pa-s/Elastic adhesive/ISO 10993 Compliant  |
| ThreeBond 1535         | 170g         | White/75Pa-s/Elastic adhesive Tin-free product  |
| ThreeBond 1535B        | 170g         | Black/90Pa-s/Elastic adhesive Tin-free product  |
| ThreeBond 1535C        | 120g         | Colorless transparent/30Pa-s/Elastic adhesive Tin-free product  |
| ThreeBond 1535D        | 150g         | Gray/25Pa-s/Elastic adhesive Tin-free product   |
| ThreeBond 1539         | 100g · 440g  | Black/100Pa-s/Single-component elastic adhesive that cures by heat fast at low temperature, plant-based (castor oil) polymer            |
| ThreeBond 1539B        | 440g         | White/100Pa-s/Single-component elastic adhesive that cures by heat fast at low temperature, plant-based (castor oil) polymer            |
| ThreeBond 1631 (30µm~) | 1,320mm×200m | Colorless transparent/From 30 µm/UV-curable, flexibility, visible light-transmissive, light resistance                                  |
| ThreeBond 2206S        | 30g · 1kg    | Black/15Pa-s/Curing at 80°C for 30 min, low halogen product   |
| ThreeBond 2296B        | 10g          | Black/18.5Pa-s/Curing at 60°C for 30 min, low-halogen product   |
| ThreeBond 3020B        | 30g          | Pale yellow/3.5Pa-s/Formation of black cured product after irradiation with ultraviolet (365 nm), Low halogen product                   |
| ThreeBond 3027G        | 1kg          | Light yellow/1.8Pa-s/For FPC reinforcement, flexibility, low water absorption   |
| ThreeBond 3027J        | 1kg          | Black/2.4Pa-s/Light blocking type, fast-curing type, low halogen product  |
| ThreeBond 3065E        | 250g         | Light yellowish transparent/7.0Pa-s/For surface adhesion (3 sec when set in combination with ThreeBond 1390F)                           |
| ThreeBond 3074C        | 30g          | Clear / 7.0 Pa-s / Refractive index 1.51, low halogen content, LED-curable, excellent curability, high transparency                     |
| ThreeBond 3081L        | 370g         | Gray white/70Pa-s/elastic sealant, heat resistance/good cold resistance, suitable for UV-CIPG applications                              |
| ThreeBond 3081P        | 350g         | Light yellow/400Pa-s/elastic sealant, heat resistance/good cold resistance, suitable for UV-CIPG applications                           |
| ThreeBond 3120B        | 30g          | Black/600mPa-s/Black UV resin for high shading, low halogen product, Epoxy type, UV-LED-curable   |
| ThreeBond 3164D        | 330ml        | Pale white / 10.0 Pa-s / UV and moisture-curing silicone, potting agent, excellent adhesion to engineering plastics                     |
| ThreeBond 3166         | 330g         | Blue/330Pa-s/elastic sealant, heat resistance, good heat and Humidity resistance, suitable for UV-CIPG applications, silicone type      |
| ThreeBond 3170B        | 50g          | Light yellow/1.8Pa-s/For bonding optical components, visible light-curable, acrylic resin-based   |
| ThreeBond 3304J        | 40g          | Silver/80Pa-s/For quartz oscillators, Extra ultra micro dispensing, silicone type   |
| ThreeBond 3331D        | 10g          | Silver/25Pa-s/Single-component heat-curing conductive resin, cured at 80°C for 60 minutes, low halogen product                          |
| ThreeBond 3333F        | 10g · 30g    | Brown / 20Pa-s / Single-component heat-curing adhesive / Excellent flexibility, cured at low temperatures, syringe type, silicone-based |
| ThreeBond 3350C        | 30g          | Conductive silver paint/room temperature dry type, low resistance type  |

### For Camera modules, Digital Cameras and Surveillance Camera

| Product name    | Volume      | Characteristics   |
|-----------------|-------------|---|
| ThreeBond 1225B | 250g        | White/18Pa-s/Moisture-curable heat dissipating resin 1.59W/m-K  |
| ThreeBond 1225C | 250g        | Gray/70Pa-s/high reliability heat dissipating resin 2.5W/m-K  |
| ThreeBond 1533  | 150g        | White/100Pa-s/Elastic adhesive, DBT-free product  |
| ThreeBond 1533C | 150g        | Translucent/100Pa-s/Elastic adhesive, DBT-free product  |
| ThreeBond 1533D | 150g        | Gray/22Pa-s/Elastic adhesive, DBT-free product  |
| ThreeBond 1533F | 150g        | Gray/180Pa-s/Elastic adhesive, DBT-free product   |
| ThreeBond 1535  | 170g        | White/75Pa-s/Elastic adhesive, Tin-free product   |
| ThreeBond 1535B | 170g        | Black/90Pa-s/Elastic adhesive, Tin-free product   |
| ThreeBond 1535C | 120g        | Colorless transparent/30Pa-s/Elastic adhesive, Tin-free product   |
| ThreeBond 1535D | 150g        | Gray/25Pa-s/Elastic adhesive, Tin-free product  |
| ThreeBond 1539  | 100g · 440g | Black / 100 Pa-s /Single-component elastic adhesive, Low-temp (60°C) & fast cure, Plant origin raw material                             |
| ThreeBond 2206S | 30g · 1kg   | Black/15Pa-s/Curing at 80°C for 30 min, low halogen product   |
| ThreeBond 2296B | 10g         | Black/18.5Pa-s/Curing at 60°C for 30 min, low-halogen product   |
| ThreeBond 2907D | 1L          | Colorless to light yellow/Single-component water repellent coating agent, drying time within 90 minutes                                 |
| ThreeBond 2955P | 250g        | Gray/120Pa-s/Moisture-curable heat dissipating resin 4.8W/m-k   |
| ThreeBond 2955Q | 250g        | Gray/103Pa-s/Moisture-curable heat dissipating resin 4.5W/m-k   |
| ThreeBond 3017D | 250g        | White/13Pa-s/Lens fixing, soft type, speedy curing, UV-LED-curable, low-halogen product   |
| ThreeBond 3017E | 250g        | White/25Pa-s/Good adhesion to materials difficult to bond, UV-LED-curable, low-halogen product  |
| ThreeBond 3017F | 250g        | White/7.5Pa-s/Good adhesion to materials difficult to bond, UV-LED-curable, low-halogen product   |
| ThreeBond 3020B | 30g         | Pale yellow/3.5Pa-s/Formation of black cured product after irradiation with ultraviolet (365 nm), low halogen product                   |
| ThreeBond 3030  | 330ml · 1kg | Milky white/16.5Pa-s/for bonding optical components, flexible   |
| ThreeBond 3033B | 333ml       | Milky white/35Pa-s/Flexibility, heat cycle resistance, high adhesive strength   |
| ThreeBond 3036  | 500g        | Gray white/35Pa-s/for bonding optical components, low linear expansion, acrylic type  |
| ThreeBond 3036G | 250g        | White/29Pa-s/Suitable for adhesion to various plastics, UV-LED-curable  |
| ThreeBond 3081L | 370g        | Gray white/70Pa-s/elastic sealing agent, good heat resistance/cold resistance, suitable for UV-CIPG applications, acrylic type          |
| ThreeBond 3081P | 350g        | Light yellow/400Pa-s/elastic sealing agent good heat resistance/cold resistance, suitable for UV-CIPG applications, acrylic type        |
| ThreeBond 3114  | 250g        | Gray white/26Pa-s/for bonding optical components, low curing shrinkage, epoxy type  |
| ThreeBond 3114J | 1kg         | White/25Pa-s/for bonding optical components, low curing shrinkage, heat resistance UV-LED-curable epoxy type                            |
| ThreeBond 3142  | 60g         | White / 60.0 Pa-s / Dual cure (UV and heat curing) for active alignment method, UV-LED curable  |
| ThreeBond 3164D | 330ml       | Pale white/10Pa-s/UV- and moisture-curable silicone, potting agent  |
| ThreeBond 3166  | 330g        | Blue / 330 Pa-s / elastic sealing agent, good heat resistance / Humidity resistance, suitable for UV-CIPG applications, silicone type   |
| ThreeBond 3168E | 500g        | Red / 90.0 Pa-s / UV-curable silicone gel, damping agent  |
| ThreeBond 3170B | 50g         | Pale yellow/1.8Pa-s/for bonding optical components, visible light curing property, acrylic type   |
| ThreeBond 3331D | 10g         | Silver/25Pa-s/Single-component heat-curing conductive resin, cured at 80°C for 60 min, low halogen product                              |
| ThreeBond 3333F | 10g · 30g   | Brown / 20Pa-s / Single-component heat-curing adhesive / Excellent flexibility, cured at low temperatures, syringe type, silicone-based |

### For Batteries

| Product name    | Volume | Characteristics  |
|-----------------|--------|--|
| ThreeBond 1153E | 330ml  | Gray/800Pa-s/Thermosetting olefin-based sealant, Gas barrier property, Chemical resistance                                   |
| ThreeBond 1170H | 1L     | Blue/225mPa-s/battery sealant/Low moisture permeability  |
| ThreeBond 1171F | 15kg   | Black/1.8Pa-s/Lithium battery sealant/Chemical resistance  |
| ThreeBond 1171G | 1L     | Colorless transparent/600mPa-s/Lithium battery sealant   |
| ThreeBond 1184E | 1kg    | Black/8.5Pa-s/Black of ThreeBond 1184  |
| ThreeBond 3035B | 100g   | White/51Pa-s/Dye-sensitized solar cell sealant   |
| ThreeBond 3118  | 100g   | White/86Pa-s/Dye-sensitized solar cell sealant   |
| ThreeBond 3178  | 300g   | White / 155 Pa-s / Heat resistant, water resistant, acid resistant, cooling liquid resistant, low moisture permeability type |

\* The Characteristics given herein are not guaranteed values, but examples of experimental values obtained by our specified test methods.

For 5G Base Station and Optical Transceiver

| Product name    | Volume    | Characteristics  |
|-----------------|-----------|--|
| ThreeBond 1225B | 250g      | White/18Pa-s/Moisture-curable heat dissipating resin 1.59W/m-K   |
| ThreeBond 1225C | 250g      | Gray/70Pa-s/high reliability heat dissipating resin 2.5W/m-K   |
| ThreeBond 1537  | 200g      | White/55Pa-s/Elastic adhesive/UL94 V-0 certified product   |
| ThreeBond 2270J | 1kg       | White/150Pa-s/Single-component heat-curing heat dissipating resin 4.2W/m-k, heat resistance, high adhesive strength                      |
| ThreeBond 2458  |           | Green / Pre-coating (MEC process), low strength type   |
| ThreeBond 2468  |           | Red / Pre-coating (MEC process), medium strength type  |
| ThreeBond 2955P | 250g      | Gray / 120Pa-s / Moisture-curing thermal conductive resin, thermal conductivity of 4.8 W/m-K   |
| ThreeBond 2955Q | 250g      | Gray / 103Pa-s / Moisture-curing thermal conductive, thermal conductivity of 4.5 W/m-K   |
| ThreeBond 3142  | 60g       | White / 60 Pa-s / Dual cure (UV and heat curing) for active alignment method   |
| ThreeBond 3166  | 330g      | Blue / 330 Pa-s / elastic sealing agent, good heat resistance / cold resistance, suitable for UV-CIPG applications, silicone type        |
| ThreeBond 3178  | 300g      | White / 155 Pa-s / Heat resistant, water resistant, acid resistant, cooling liquid resistant, low moisture permeability type             |
| ThreeBond 3331D | 10g       | Silver/25Pa-s/one-component thermosetting conductive resin, cured at 80°C for 60 min, low halogen product.                               |
| ThreeBond 3333F | 10g · 30g | Brown / 20 Pa-s / Single-component heat-curing adhesive / Excellent flexibility, cured at low temperatures, syringe type, silicone-based |

For Car Mounted Display / Camera

| Product name           | Volume       | Characteristics  |
|------------------------|--------------|--|
| ThreeBond 1225B        | 250g         | White/18Pa-s/Moisture-curable heat dissipating resin 1.59W/m-K   |
| ThreeBond 1225C        | 250g         | Gray/70Pa-s/high reliability heat dissipating resin 2.5W/m-K   |
| ThreeBond 1535         | 170g         | White/75Pa-s/Elastic adhesive Tin-free product   |
| ThreeBond 1535B        | 170g         | Black/90Pa-s/Elastic adhesive Tin-free product   |
| ThreeBond 1535C        | 120g         | Colorless transparent/30Pa-s/Elastic adhesive Tin-free product   |
| ThreeBond 1535D        | 150g         | Gray/25Pa-s/Elastic adhesive Tin-free product  |
| ThreeBond 1539         | 100g · 440g  | Black/100Pa-s/Single-component elastic adhesive that cures by heat fast at low temperature, plant-based (castor oil) polymer |
| ThreeBond 1631 (30µm~) | 1,320mmx200m | Colorless transparent/From 30 µm/UV-curable, flexibility, visible light-transmissive, light resistance                       |
| ThreeBond 2206S        | 30g · 1kg    | Black/15Pa-s/Curing at 80°C for 30 min, low halogen product  |
| ThreeBond 2270J        | 1kg          | White/150Pa-s/Single-component heat-curing heat dissipating resin 4.2W/m-k, heat resistance, high adhesive strength          |
| ThreeBond 3020B        | 30g          | Pale yellow/3.5Pa-s/Formation of black cured product after irradiation with ultraviolet (365 nm), Low halogen product        |
| ThreeBond 3027J        | 1kg          | Black/2.4Pa-s/Light blocking type, fast-curing type, low halogen product   |
| ThreeBond 3036         | 500g         | Gray white/35Pa-s/for bonding optical components, low linear expansion, acrylic type   |
| ThreeBond 3036G        | 250g         | White/29Pa-s/Suitable for adhesion to various plastics, UV-LED-curable   |
| ThreeBond 3114         | 250g         | Gray white/26Pa-s/for bonding optical components, low curing shrinkage, epoxy type   |
| ThreeBond 3114J        | 1kg          | White/25Pa-s/for bonding optical components, low curing shrinkage, heat resistance, UV-LED-curable, epoxy type               |
| ThreeBond 3120B        | 30g          | Black/600mPa-s/Black UV resin for high shading, low halogen product, Epoxy type, UV-LED-curable                              |
| ThreeBond 3315F        | 1kg          | Conductive carbon resin/Low temperature-curable, spot bonding, flexibility   |
| ThreeBond 3331D        | 10g          | Silver/25Pa-s/Single-component heat-curing conductive resin, cured at 80°C for 60 min, low halogen product                   |
| ThreeBond 3350C        | 30g          | Conductive silver paint/room temperature dry type, low resistance type   |

\* The values shown in the characteristics table are examples from actual measurement values, not guaranteed values.

For General Purposes Related to Electrics and Electronics

| Product name    | Volume               | Characteristics  |
|-----------------|----------------------|--|
| ThreeBond 1220G | 100g                 | Milky white/65Pa-s/alcohol-releasing type  |
| ThreeBond 1234B | 330ml                | Gray/400Pa-s/Single-component heat-curable silicone, high adhesion, high durability  |
| ThreeBond 1537  | 200g                 | White/55Pa-s/Elastic adhesive/UL94 V-0 certified product   |
| ThreeBond 1771E | 50g                  | Yellow/2.0mPa-s/Light curability added type instantaneous adhesive   |
| ThreeBond 1773E | 20g · 500g           | Yellow/150mPa-s/Light curability added type instantaneous adhesive   |
| ThreeBond 2081D | 200g SET             | Main agent: Light yellowish white/Curing agent: Brownish transparent, for bonding soft vinyl chloride materials              |
| ThreeBond 2082C | 200g SET             | Main agent: White/Curing agent: Brownish transparent, for high shearing adhesion   |
| ThreeBond 2086M | 50ml SET<br>200g SET | Main agent: Colorless and transparent/Curing agent: Light yellowish transparent, low-viscosity fast-curing type              |
| ThreeBond 2087  | 90g SET              | Main agent: Light yellow/Curing agent: Light yellow, normal-temperature-curing type for structures                           |
| ThreeBond 2088E | 100g SET             | Main agent: Yellowish transparent/Curing agent: Yellowish brown and transparent, High thermal adhesiveness                   |
| ThreeBond 2202C | 1kg                  | White/27Pa-s/Low-temperature curable type/ISO 10993 Compliant  |
| ThreeBond 2212B | 1kg                  | Black/25Pa-s/Curing at 80°C for 30 min, for potting  |
| ThreeBond 2212C | 1kg                  | Reddish brown/25Pa-s/Curing at 80°C for 30 min, for potting  |
| ThreeBond 2212Q | 1kg                  | Black/15Pa-s/Low-halogen product   |
| ThreeBond 2247D | 3kg                  | Milky white/45Pa-s/Curing at 150°C for 30 min, high peel strength  |
| ThreeBond 3013Q | 330ml · 1kg          | Blue/23Pa-s/Potting of electric and electronic components, rubber elasticity, heat resistance, oil resistance                |
| ThreeBond 3017B | 500g                 | Milky white/16Pa-s/Good adhesion to materials difficult to bond, good moisture resistance                                    |
| ThreeBond 3033L | 330ml · 1kg          | Blue/24.6Pa-s/flexible, high adhesive strength   |
| ThreeBond 3042B | 1kg                  | Colorless and transparent/500mPa-s/General-use type, good transparency, fast curing  |
| ThreeBond 3042C | 250g                 | Colorless and transparent/1500mPa-s/General-use type, good transparency, fast curing   |
| ThreeBond 3049  | 250g                 | Light yellow / 500 mPa-s / Biomass mark certified product (biomass degree: 45%), LED-curable, lowviscosity                   |
| ThreeBond 3056K | 333ml                | Greenish transparent/3.6Pa-s/With moisture-curability added, suitable for bonding and sealing                                |
| ThreeBond 3177  | 20g                  | Yellowish transparent/1.2Pa-s/With moisture-curability added, moisture resistance, good heat resistance, ISO 10993 Compliant |
| ThreeBond 3301W | 200g                 | Single-component heat-curing conductive resin/epoxy-based/solventless type/Silver  |
| ThreeBond 3380  | 60g SET              | Two-component room temperature curing conductive resin/epoxy-based/solventless type/Silver                                   |
| ThreeBond 3381  | 500g SET             | Two-component room temperature curing conductive resin/acrylic resin-based/solventless type/Nickel                           |
| ThreeBond 3921  | 250g · 1kg           | Red/5.1Pa-s/Less-odor acrylic resin-based structural adhesive main agent, good adhesion to a wide variety of materials       |
| ThreeBond 3923  | 1kg                  | Pale white/3.0Pa-s/Honeymoon-type acrylic resin-based structural adhesive main agent, good heat resistance                   |
| ThreeBond 3926  | 250g · 1kg           | Blue/5.1Pa-s/Less-odor acrylic resin-based structural adhesive curing agent, good adhesion to a wide variety of materials    |
| ThreeBond 3928  | 1kg                  | Green/3.0Pa-s/Honeymoon-type acrylic resin-based structural adhesive curing agent, good heat resistance                      |
| ThreeBond 6651F | 180g · 420g · 18kg   | Non-flammable parts cleaner / Non-hazardous substance  |
| ThreeBond 6651G | 18kg                 | Non-flammable parts cleaner / Non-hazardous substance / Low resin attack property  |
| ThreeBond 7721  | 20g                  | Colorless to light yellowish transparent/5.0mPa-s/Non-whitening type   |
| ThreeBond 7738  | 20g                  | Light yellowish transparent/5.0Pa-s/Extremely high peel strength, impact-resistant type                                      |
| ThreeBond 7741  | 20g                  | Light yellowish transparent/2.0mPa-s/Standard type   |
| ThreeBond 7781  | 20g · 50g            | Light yellowish transparent/2.0mPa-s/Extremely-fast-curing type  |
| ThreeBond 7782  | 20g                  | Light yellowish transparent/15mPa-s/Extremely-fast-curing type   |
| ThreeBond 7784  | 20g                  | Light yellowish transparent/160mPa-s/Extremely-fast-curing type  |
| ThreeBond 7785  | 20g                  | Light yellowish transparent/500mPa-s/Extremely-fast-curing type  |
| ThreeBond 7786  | 20g                  | Light yellowish transparent/1.0Pa-s/Extremely-fast-curing type   |
| ThreeBond 7789  | 20g                  | Light yellowish transparent/Gel/Extremely-fast-curing type   |
| ThreeBond 7796  | 100ml                | Curing accelerating agent/Faint-odor type  |
| ThreeBond 7797  | 100ml                | Multi-primer for materials difficult to bond   |

\* The Characteristics given herein are not guaranteed values, but examples of experimental values obtained by our specified test methods.

# Application Equipment

ThreeBond develops and sells sealants and adhesives as well as the equipment to apply and pressure feed them to maximize their performance. As a manufacturer with full knowledge of sealants and adhesives, ThreeBond enables to reduce cost and improve

productivity, product quality, and working environment by developing such equipment. To provide further added value for customers, ThreeBond has been making efforts to develop and sell the equipment that incorporates new application and pressure feeding technologies.

Application Equipment

## Features of ThreeBond Application Equipment

- ① **Applies the required amount of material in the required shape.**  
ThreeBond offers valves and nozzles to apply materials in the shape of points, lines, and coatings.
- ② **Maximizes sealant and adhesive performance.**  
As a manufacturer thoroughly familiar with properties of sealants and adhesives, ThreeBond develops and designs the equipment for applying and pressure feeding each material.
- ③ **Applies and pressure feeds sealants and adhesives in all container types.**  
ThreeBond offer equipment for applying and pressure feeding sealants and adhesives in various forms of containers, ranging from syringes to pails.
- ④ **Dedicated equipment design and manufacture.**  
ThreeBond design and manufacture dedicated equipment to meet customer needs, ranging from simple applicators for low-volume production to custom-designed dispensing machines equipped with multiple functions for high-volume and multiple types of production.

The main components of a dispensing machine are as follows:

- Pressure feeder: Equipment including pumps to pressure feed materials
- Hoses: Piping used to pressure feed material from the pump to the valve
- Valves: Used to control the flow of material
- Nozzles: Attached to the valve and used to adjust the shape/size in which material is applied
- Controllers: Equipment to control the valve and pump
- Drive units: Robots that automate the application process

ThreeBond provide dispensing machines that can meet customer needs by combining various products that incorporate ThreeBond's unique technologies and features.

## For selection of Application Equipment

ThreeBond offers the following products according to the properties of each material, to maximize its performance. To provide the Application Equipment that meets customer requirements, we deploy staff who is specialized in the equipment and has full knowledge of sealants and adhesives at home and abroad. We can respond to a wide range of customer needs from delivery of the devices to provision of after-sales services. To select equipment suitable for our sealants and adhesives, contact one of our sales engineers.

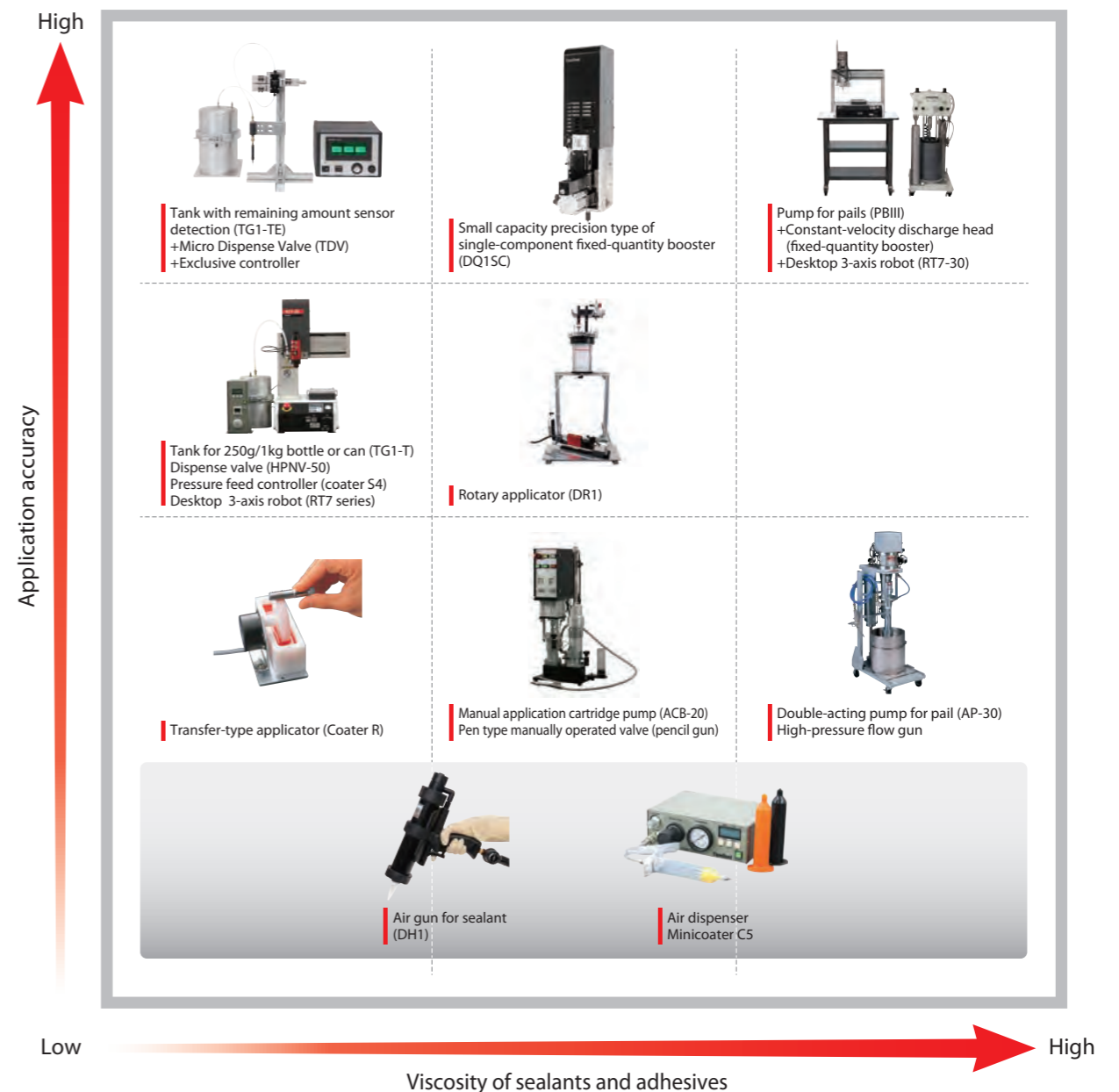



# TB1100,1200 series

- A lineup of devices that can handle small-amount and large-amount sealants and adhesives is available.
- They are suitable for the bead application of solvent-volatilization-type and moisture-curable-type liquid gaskets.
- Dispensers that can apply a fixed quantity of a sealant and an adhesive without waste are available.
- A unit that can reduce the amount of a remaining liquid agent in a pail is available as an option. (Some conditions must be met.)

# TB1300 series

- Lineup of products for improvement of productivity and workability
- The RTM and RTM-H Series enable products that meet customer requirements to be designed and manufactured.

- \* ACB...Automatic Cartridge Booster
- \* PCB...Power Cartridge Booster
- \* RTM...Rotary Transfer Motor
- \* RTA-H...Rotary Transfer Air-motor by HandApplication

## Tube

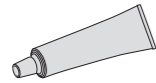

**Air gun for sealant (DH1)**  
 Applicable package type: Cartridge/Tube  
 This is a pneumatic sealant gun.  
 \*This product may not be compatible with some cartridge and tube types. For the details, contact one of our sales engineers.  
 (Individual catalog number #36)



**Tank for tube Air dispenser (minicoater C5)**  
 Applicable package type: Tube  
 The discharge amount is adjusted by means of the dispensing time and tank pressure.  
 \*This product may not be compatible with some tube types. For the details, contact one of our sales engineers.  
 (Individual catalog number #2)

## Cartridge



**Cartridge-type pump (PCB-20)**  
 This is a high-pressure feeding pump designed for automatic application. When it is combined with a robot, uniform linear application is possible. Automatic application by machine is possible.  
 (Individual catalog number #6)



**Dedicated to surface application Adhesive discharging valve (RV-SN Series)**  
 This is an adhesive discharging valve to apply material in plane-like or band-like form. Automatic application by machine is possible.  
 (Individual catalog number #30)

## 1-kg can

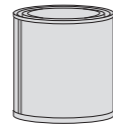

**Tank for 1-kg or less bottle or can (TG1-T)**  
**Pen type manually operated valve (pencil gun)**  
 This dispenser is for a low-viscosity material. Dispensing is done by pulling the gun lever. Automatic application by machine is impossible.  
 (Individual catalog number #3)



**Tank for 1-kg or less bottle or can (TG1-T)**  
**Needle type dispense valve (HPNV-50)**  
**Pressure controller (coater S4)**  
**Desktop robot (RT7 Series)**  
 This device pressure-feeds a material from a tank and applies the material by controlling the valve. When the dispenser is combined with a robot, it applies the material appropriately to a programmed position. Automatic application by machine is possible.  
 (Individual catalog number #14)

## Pail



**Double-acting pump for pails (AP-30)**  
**High-pressure flow gun type (High-pressure flow gun)**  
 This dispenser is excellent in high-speed dispense and operability as the result of a combination of high-pressure feeding pump for pails and a high-pressure flow gun. Automatic application by machine is impossible.  
 (Individual catalog number #7)



**Single-acting pump for pails (PBIII-45)**  
 This is a pump for streaming a high viscosity liquid agent efficiently. When it is combined with a robot, uniform linear application is possible. Automatic application by machine is possible.  
 (Individual catalog number #8)



**Pump for pails (PB III)**  
**Single-component fixed-quantity booster (fixed-quantity booster)**  
**Desktop robot (RT7 Series)**  
 When a high-pressure feeding pump designed for automatic application and a constant-speed dispense head are combined with a robot, high-precision and uniform linear application that is not affected by changes in the environmental temperature is possible. Automatic application by machine is possible.  
 (Individual catalog number #9)

## Bottle

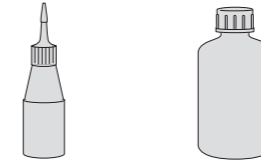

**Transfer-type simple applicator (coater R)**  
 Application to threaded portion is done by lightly pressing the threaded portion of a bolt to the outer portion of the rotating rotor. Automatic application by machine is impossible.  
 (Individual catalog number #10)



**Rotary applicator (DR1 Series)**  
 This is a unit for applying and pressure feeding anaerobic sealant to the inside of a cylinder. Automatic application by machine is possible.  
 (Individual catalog number #13)



**Syringe dispenser (minicoater C5)**  
 The discharge amount is adjusted by means of the dispensing time and air pressure. Automatic application by machine is possible.  
 (Individual catalog number #11)



**Manual rotary applicator (RTA-H)**  
 This is a rotary coating machine for coating the inside of a cylinder with a material manually. Automatic application by machine is impossible.  
 (Individual catalog number #12)

\* ThreeBond is abbreviated to TB.

# TB1500 series

- Lineup of products for improvement of productivity and workability  
 - Applicators suitable to a wide range of adhesives, such as solvent-volatilization type, moisture-curable type, and aqueous pressure-sensitive type, can be selected.

# TB1700, 7700 series

- Application of an instantaneous adhesive that is difficult to handle is automated, which enables a work environment and application quality to be improved.

- \* LVCT-AC...Low Viscosity Cartridge Tank - Automatic Connection
- \* HPV-50...Pressure Needle Valve - Type 50
- \* DPB-40...Diaphragm Power Booster
- \* TDV...Triple Diaphragm ValveApplication

## Tube

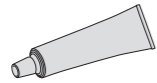

**Air gun for sealant (DH1)**

Applicable package type: Cartridge/Tube  
 This is a pneumatic sealant gun.  
 \*This product may not be compatible with some cartridge and tube types. For the details, contact one of our sales engineers.

Individual catalog number #36



**Tank for tube Air dispenser (minicoater C5)**

Applicable package type: Tube  
 The discharge amount is adjusted by means of the dispensing time and tank pressure.

\*This product may not be compatible with some tube types. For the details, contact one of our sales engineers.

Individual catalog number #2

## Cartridge



**Air gun for sealant (DH1)**

Applicable package type: Cartridge/Tube  
 This is a pneumatic sealant gun.

Individual catalog number #36



**Cartridge-type tank (TC2) Dispensing valve (HPNV-50) Controller for pressure (coater S4) Desktop robot (RT7 Series)**

This unit pressure-feeds a material from the cartridge and controls the open/close valve to apply the material. When the controller is combined with a robot, it will apply the material to a programmed position.

Automatic application by machine is possible.  
 Individual catalog number #15

## 1-kg can



**Tank for 1-kg or less bottle or can (TG1-T) Pen type manually operated valve (pencil gun)**

This dispenser is for a low-viscosity material. Dispensing is done by pulling the gun lever. Automatic application by machine is impossible.

Individual catalog number #3



**Tank for 1-kg or less bottle or can (TG1-T) Needle type dispense valve (HPNV-50) Pressure controller (coater S4) Desktop robot (RT7 Series)**

This device pressure-feeds a material from a tank and applies the material by controlling the valve. When the dispenser is combined with a robot, it applies the material appropriately to a programmed position.

Automatic application by machine is possible.  
 Individual catalog number #14

## Bottle



**Tubing pump**

This dispenser is suitable for dispensing low-viscosity material in a very small amount.



**Tank with level sensor detection (TG1-TE) Extremely small-quantity and fixed-quantity valve (TDV) Exclusive controller**

This is an extremely small-quantity instant adhesives dispenser with excellent durability and stability. Automatic application by machine is possible.

Individual catalog number #17

# TB2000 & 2100, 2200 series

- Lineup of products for improvement of productivity and workability
- Applicators are available for each of the single-component type and the two-component type.
- The two-component type can be set, according to a mixing ratio.

# TB3000, 3100 series

- UV-curing type, anaerobic-curing type, and moisture-curing type
- Applicators for each of the above types are available.
- Auxiliary equipment needed for the process from application to curing is available.
- Equipment suitable for CIPG application (design of a special-purpose machine)

\* CIPG...Cured in Place Gasket

## Twin cartridge



### Hand gun for two-component liquid cartridge

This hand gun mixes a two-component liquid agent with its static nozzle and injects it.

Automatic application by the machine is impossible.

Individual catalog number #18

## 1-kg can



### Syringe dispenser (minicoater C5)

The discharge amount is adjusted by means of the dispensing time and air pressure.

Automatic application by machine is possible.

Individual catalog number #1



### Tank for 1-kg or less bottle or can (TG1-T) Pen type manually operated valve (pencil gun)

This dispenser is for a low-viscosity material.

Dispensing is done by pulling the gun lever.

Automatic application by machine is impossible.

Individual catalog number #3



### Tank for 1-kg or less bottle or can (TG1-T) Needle type dispense valve (HPNV-50) Pressure controller (coater S4) Desktop robot (RT7 Series)

This device pressure-feeds a material from a tank and applies the material by controlling the valve.

When the dispenser is combined with a robot, it applies the material appropriately to a programmed position.

Automatic application by machine is possible.

Individual catalog number #14



### One-component dispenser with a gear pump/ Two-components-mixing dispenser

This dispenser pressure-feeds an agent with its gear pump. It pressure-feeds each of two liquids with the gear pump and mix them with the dynamic mixer to inject the mixture.

This is manufactured, according to specifications, such as a mixing ratio and injection speed.

Automatic application by the machine is possible.

Individual catalog number #19



### Dedicated to surface application Adhesive discharging valve RV-SN Series

This is an adhesive discharging valve to apply material in plane-like or band-like form.

Automatic application by machine is possible.

Individual catalog number #30



### Pump for 1-kg cans PH1-20

This is a pump for high-pressure feeding of liquid agents loaded in a 1 kg metal can. 1 kg cans of liquid agent can be opened with a can opener and set to the pump without transferring liquid.

Individual catalog number #35

## Pail



### Reciprocating pump for pails (AP-30) High-pressure flow gun (H-FLG)

This dispenser is excellent in high-speed injection and operability as the result of combination of a high-pressure feeding pump for pails and a high-pressure flow gun.

Automatic application by the machine is impossible.

Individual catalog number #7



### Single-acting pump for pails (PBIII-45)

This is a high-pressure feeding pump for automatic application. When it is combined with the robot, uniform linear application is possible.

Automatic application by the machine is possible.

Individual catalog number #8

## Syringe



### Syringe dispenser (minicoater C5)

The discharge amount is adjusted by means of the dispensing time and air pressure.

Automatic application by machine is possible.

Individual catalog number #11

## 250-g/1-kg bottle

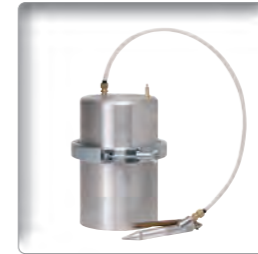
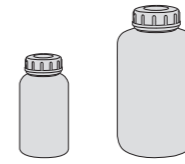

### Tank for 1-kg or less bottle or can (TG1-T) Pen type manually operated valve (pencil gun)

This dispenser is for a low-viscosity material.

Dispensing is done by pulling the gun lever.

Automatic application by machine is impossible.

Individual catalog number #3

## Cartridge



### Air gun for sealant (DH1)

Applicable package type: Cartridge/Tube

This is a pneumatic sealant gun.

\*This product may not be compatible with some cartridge and tube types. For the details, contact one of our sales engineers.

Individual catalog number #36



### Cartridge-type tank (TC2) Dispensing valve (HPNV-50) Controller for pressure (coater S4) Desktop robot (RT7 Series)

This unit pressure-feeds a material from the cartridge and controls the open/close valve to apply the material.

When the controller is combined with a robot, it will apply the material to a programmed position.

Automatic application by machine is possible.

Individual catalog number #15



### Dedicated to surface application Adhesive discharging valve RV-SN Series

This is an adhesive discharging valve to apply material in plane-like or band-like form.

Automatic application by machine is possible.

Individual catalog number #30

\* ThreeBond is abbreviated to TB.

# Quick chart for needle, nozzle, syringe and barrel

## Standard metal needles with high versatility



Standard metal needles with high versatility (SNA Series)

Unit : mm

| Gauge             | 12G  | 13G  | 14G  | 15G  | 16G  | 17G  | 18G  | 19G  | 20G  | 21G  |
|-------------------|------|------|------|------|------|------|------|------|------|------|
| Internal diameter | 2.27 | 1.94 | 1.64 | 1.43 | 1.25 | 1.11 | 0.92 | 0.72 | 0.61 | 0.52 |
| Outer diameter    | 2.77 | 2.40 | 2.10 | 1.83 | 1.65 | 1.49 | 1.28 | 1.08 | 0.91 | 0.82 |

| Gauge             | 22G  | 23G  | 24G  | 25G  | 26G  | 27G  | 28G  | 30G  | 31G  | 32G  |
|-------------------|------|------|------|------|------|------|------|------|------|------|
| Internal diameter | 0.42 | 0.34 | 0.31 | 0.26 | 0.25 | 0.21 | 0.18 | 0.14 | 0.13 | 0.10 |
| Outer diameter    | 0.72 | 0.64 | 0.57 | 0.52 | 0.46 | 0.42 | 0.36 | 0.32 | 0.26 | 0.23 |

## Plastic needle



Plastic needle (PN Series)

Unit : mm

| Gauge             | 15G  | 16G  | 17G  | 18G  | 19G  | 20G  | 21G  | 22G  | 23G  | 24G  |
|-------------------|------|------|------|------|------|------|------|------|------|------|
| Internal diameter | 1.43 | 1.26 | 1.06 | 0.97 | 0.78 | 0.66 | 0.57 | 0.47 | 0.40 | 0.31 |
| Outer diameter    | 1.83 | 1.65 | 1.50 | 1.27 | 1.08 | 0.90 | 0.81 | 0.72 | 0.64 | 0.56 |

| Gauge             | 25G  | 26G  | 27G  |
|-------------------|------|------|------|
| Internal diameter | 0.29 | 0.25 | 0.20 |
| Outer diameter    | 0.51 | 0.46 | 0.41 |

## PTFE nozzle



PTFE nozzle (TN Series)

Unit : mm

| Gauge             | 13G  | 14G  | 15G  | 16G  | 17G  | 18G  | 19G  | 20G  | 21G  | 22G  |
|-------------------|------|------|------|------|------|------|------|------|------|------|
| Internal diameter | 1.50 | 1.35 | 1.19 | 1.07 | 0.96 | 0.86 | 0.68 | 0.56 | 0.46 | 0.38 |
| Outer diameter    | 2.10 | 1.95 | 1.79 | 1.67 | 1.56 | 1.46 | 1.18 | 1.06 | 0.92 | 0.84 |

## Double thread screw taper nozzle



Double thread screw taper nozzle (TPND Series)

Unit : mm

| Gauge             | 12G  | 14G  | 16G  | 18G  | 20G  | 22G  | 25G  | 27G  | 30G  |
|-------------------|------|------|------|------|------|------|------|------|------|
| Internal diameter | 2.40 | 1.60 | 1.19 | 0.84 | 0.61 | 0.40 | 0.25 | 0.20 | 0.15 |

\* Quoted from Musashi Engineering, Inc.

\* Please use same manufacturer nozzle and syringes.

## Musashi Engineering, Inc.

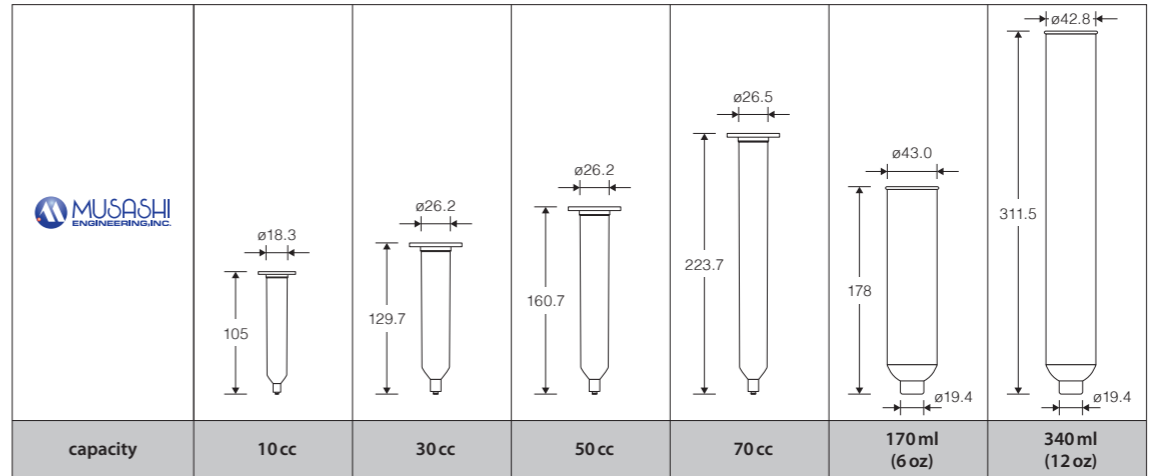

\* This color is clear

## Nordson K.K.

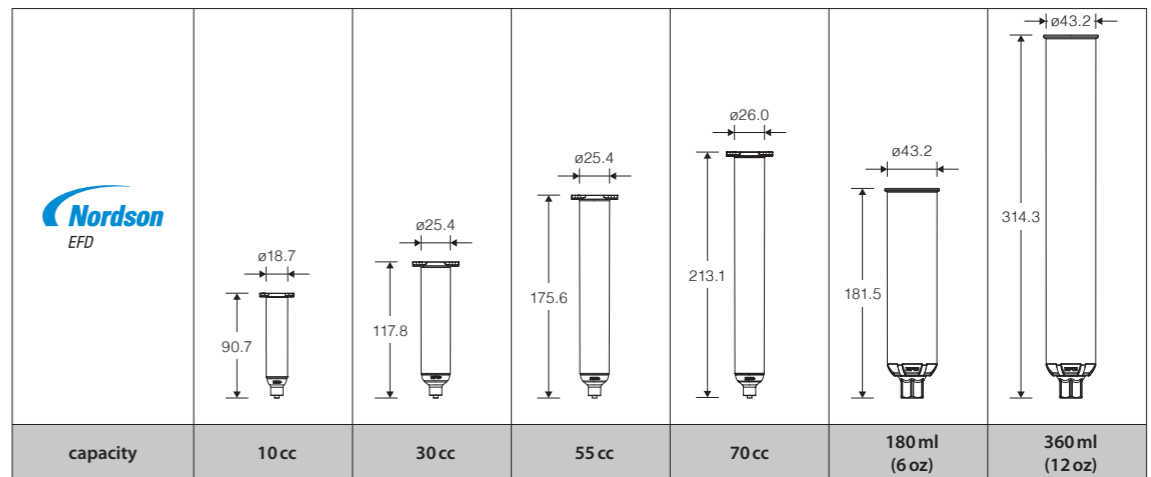

## SAN-EI TECH LTD.

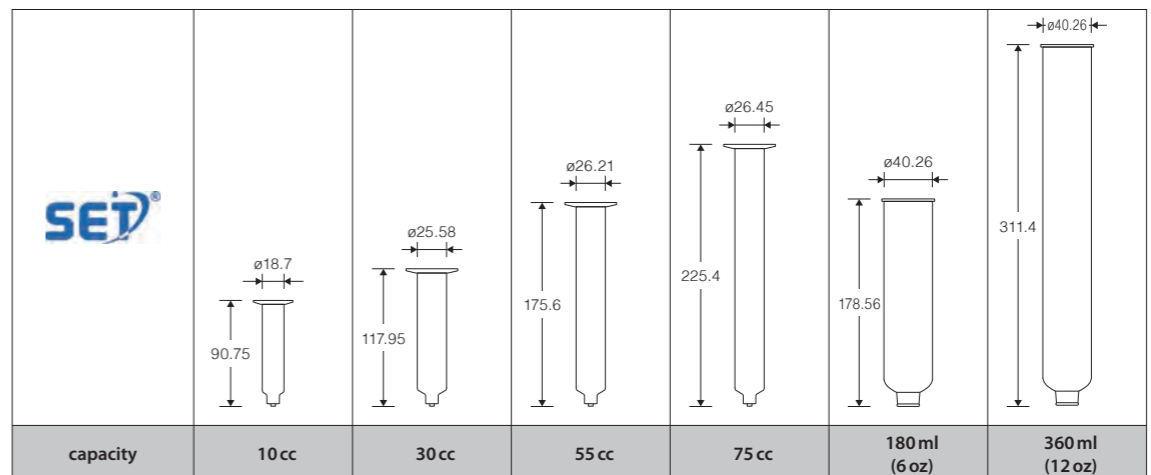

\* This is reference dimensions.

**For Industrial Use Only**

Do not use this product for household purposes.

This product was developed for general industrial use. Before using this product, the user must accept the following terms:

- The technical data given herein are not guaranteed values, but examples of experimental values obtained by our specified test methods. We do not guarantee that the uses described herein do not conflict with any intellectual property right.
- Users are asked to examine whether the product is appropriate to the purpose of use and can be used safely before they use it and bear all responsibilities and hazards involved in its use. Never use the product for medical implants that may be embedded, injected or left in the body.
- We are not liable for personal injury or property damage caused by improper handling of this product. If the properties and usage of this product are unknown, never use it.
- For detailed safety information of the product, see the Safety Data Sheet (SDS). To obtain the SDS, contact our sales office or customer service center.
- Information in this technical document is subject to change at our discretion without notice.

• The following are trademarks or registered trademarks of ThreeBond Co., Ltd.  
 ThreeBond MEC Sealock ThreeLock DryLock GOLD LABEL ThreeSealer ThreeSheetPacking PASTAR ThreeRuster  
 Ultra Glass Coating(Logo) TYREPANDO THREEBOND TAPE

Creating Our Future From a Single Drop

**ThreeBond International, Inc.**

Offices in Cincinnati, San Jose, and Detroit  
 Flexible regional sales support

A global network to meet customer needs in 60 locations including: Mexico, Brazil, France, the UK, Germany, Italy, the Czech Republic, Singapore, Thailand, Malaysia, the Philippines, India, Indonesia, China, Taiwan, Korea, Australia, and Japan.

6184 Schumacher Park Dr.  
 West Chester, OH 45069      threebond.com  
 TEL: 513-779-7300      EMAIL: sales@threebond.com

Your Request: